

Quantum mechanics calculation for material science

By

Kunio TAKAHASHI

Tokyo Institute of Technology,

Tokyo 152-8552, JAPAN

Phone/Fax +81-3-5734-3915

takahak@mep.titech.ac.jp

<http://www.mep.titech.ac.jp/KTakahashi/>

This is a material for the class of Takahashi. Bonus point will be given to the student who has found some mistype etc... and report it to Takahashi. Thank you.

1. Classical mechanics to quantum mechanics

(keywords : analytical mechanics, matrix mechanics, wave mechanics)

■ Equation of motion

- Newton

$$F = m\ddot{x}$$

- Hamilton's canonical equations

$$\frac{dq_i}{dt} = \frac{dH}{dp_i} \quad \frac{dp_i}{dt} = -\frac{dH}{dq_i}$$

■ Matter wave (de Broglie wave)

$$\lambda = h / p$$

■ Uncertainty relation

$$\Delta q \Delta p \geq \hbar / 2$$

■ Real number to linear operator as quantity

$$p_x \rightarrow -i\hbar \frac{\partial}{\partial x}, p_y \rightarrow -i\hbar \frac{\partial}{\partial y}, p_z \rightarrow -i\hbar \frac{\partial}{\partial z}$$

$$\int \psi^*(x, y, z) \psi(x, y, z) dx dy dz$$

$$\int \psi^*(x, y, z) \psi(x, y, z) dx dy dz = 1$$

■ Eigenvalue as observable and

Wave function which express a state of system

$$\chi = \int \psi^*(x, y, z) \mathbf{X} \psi(x, y, z) dx dy dz$$

■ Schrödinger equation

$$i\hbar \frac{\partial \psi}{\partial t} = \mathbf{H} \psi$$



When Hamiltonian is independent of time.

$$\mathbf{H} \psi(q) = \epsilon \psi(q)$$

2. Equation to be solved

Hartree Fock approximation: Materials we are considering are ...

- Schrödinger equation $\mathbf{H}\psi = \varepsilon\psi$
- Hamiltonian
 - Even if assuming only Coulomb interaction

$$\mathbf{H} = -\frac{\hbar^2}{2m} \sum_{i=1}^N \nabla_i^2 + \frac{1}{4\pi\epsilon_0} \left(\sum_{\substack{i,j=1 \\ (i>j)}}^N \frac{e^2}{R_{e,i,j}} - \sum_{a=1}^M \sum_{i=1}^N \frac{Z_a e^2}{r_{a,i}} + \sum_{\substack{a,b=1 \\ (a>b)}}^M \frac{Z_a Z_b e^2}{R_{i,a,b}} \right)$$

- Wave function; Slater determinant
 - Anti-symmetric property of Fermion
 - Molecular orbitals must be arbitrary.

$$\psi(\mathbf{r}_1, \dots, \mathbf{r}_N) = \frac{1}{\sqrt{N!}} \begin{vmatrix} \phi_1(\mathbf{r}_1) & \dots & \phi_1(\mathbf{r}_N) \\ \vdots & & \vdots \\ \phi_N(\mathbf{r}_1) & \dots & \phi_N(\mathbf{r}_N) \end{vmatrix}$$

- Do you know exact solution ?

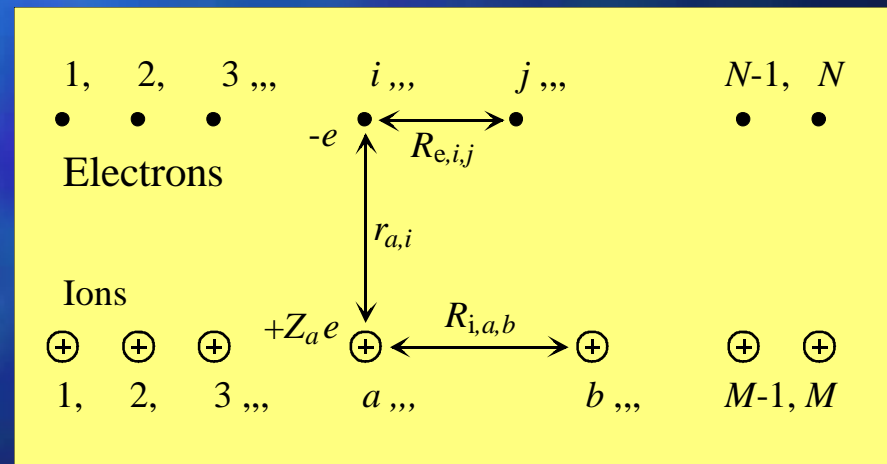
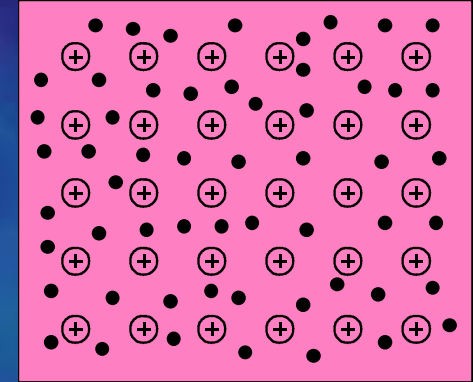

3. Simple examples (1)

Materials we are considering are ...

$$\mathbf{H} = -\frac{\hbar^2}{2m} \sum_{i=1}^N \nabla_i^2 + \frac{1}{4\pi\epsilon_0} \left(\sum_{\substack{i,j=1 \\ (i>j)}}^N \frac{e^2}{R_{e,i,j}} - \sum_{a=1}^M \sum_{i=1}^N \frac{Z_a e^2}{r_{a,i}} + \sum_{\substack{a,b=1 \\ (a>b)}}^M \frac{Z_a Z_b e^2}{R_{i,a,b}} \right)$$

■ One electron systems

- One ionic core : H (neutral atom)
: He⁺, Li²⁺, Be³⁺, B⁴⁺, C⁵⁺, N⁶⁺, O⁷⁺, ... (ions)
- Many ionic cores : H₂⁺ (ion)
: charged molecules

$$\psi(\mathbf{r}_1, \dots, \mathbf{r}_N) = \frac{1}{\sqrt{N!}} \begin{vmatrix} \phi_1(\mathbf{r}_1) & \dots & \phi_1(\mathbf{r}_N) \\ \vdots & & \vdots \\ \phi_N(\mathbf{r}_1) & \dots & \phi_N(\mathbf{r}_N) \end{vmatrix}$$

■ Many electron systems

- One ionic core : He, Li, Be, B, C, N, O, ... (isolated atoms)
- Many ionic cores : general problem we want to solve.

■ Jellium

: approximation for metals

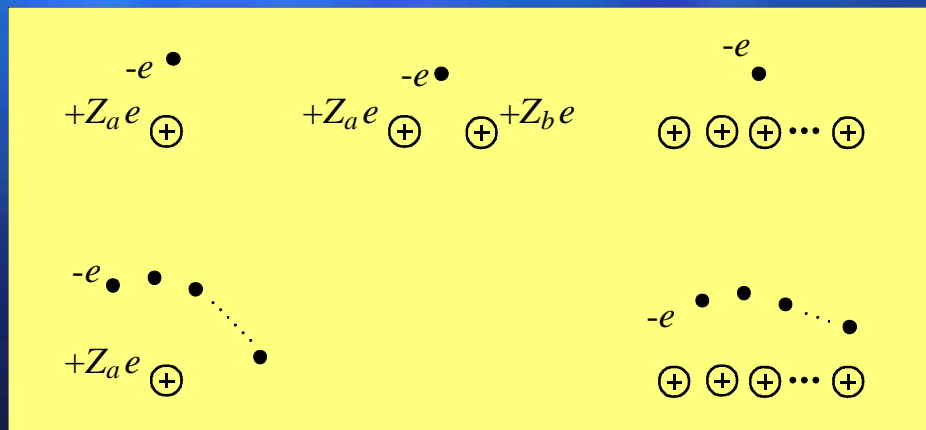

3. Simple examples (2)

Materials we are considering are ...

$$\mathbf{H} = -\frac{\hbar^2}{2m} \sum_{i=1}^N \nabla_i^2 + \frac{1}{4\pi\epsilon_0} \left(\sum_{\substack{i,j=1 \\ (i>j)}}^N \frac{e^2}{R_{e,i,j}} - \sum_{a=1}^M \sum_{i=1}^N \frac{Z_a e^2}{r_{a,i}} + \sum_{\substack{a,b=1 \\ (a>b)}}^M \frac{Z_a Z_b e^2}{R_{i,a,b}} \right)$$

■ One electron systems

- One ionic core : H (neutral atom)
: He⁺, Li²⁺, Be³⁺, B⁴⁺, C⁵⁺, N⁶⁺, O⁷⁺, ... (ions)
- Many ionic cores : H₂⁺ (ion)
: charged molecules

$$\psi(\mathbf{r}_1, \dots, \mathbf{r}_N) = \frac{1}{\sqrt{N!}} \begin{vmatrix} \phi_1(\mathbf{r}_1) & \dots & \phi_1(\mathbf{r}_N) \\ \vdots & & \vdots \\ \phi_N(\mathbf{r}_1) & \dots & \phi_N(\mathbf{r}_N) \end{vmatrix}$$

■ Many electron systems

- One ionic core : He, Li, Be, B, C, N, O, ... (isolated atoms)
- Many ionic cores : general problem we want to solve.

■ Jellium

: approximation for metals

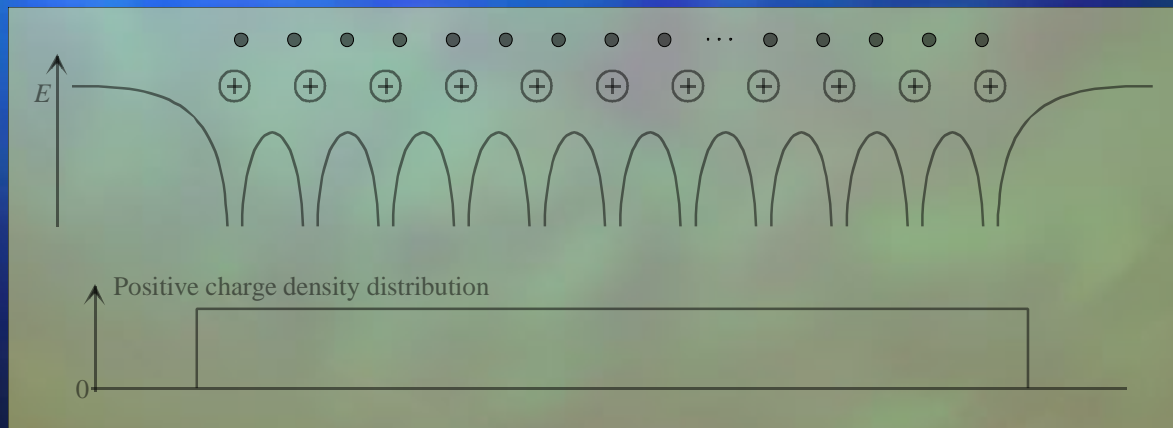

4. Isolated H atom (1)

as a one electron and one ion system

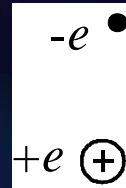

- Born-Oppenheimer approximation

$$\mathbf{H}\varphi = E\varphi \quad \mathbf{H} = -\frac{\hbar^2}{2m}\nabla^2 - \frac{e^2}{4\pi\epsilon_0 r}$$

$$\varphi_{n,l,m}(r, \theta, \phi) = -\sqrt{\left(\frac{2}{na_0}\right)^3 \frac{(n-l-1)!}{2n\{(n+l)!\}^3}} \left(\frac{2r}{na_0}\right)^l \exp\left(-\frac{r}{na_0}\right) L_{n+l}^{2l+1}\left(\frac{r}{na_0}\right) \\ \times \sqrt{\frac{2l+1}{2} \frac{(l-|m|)!}{(l+|m|)!}} P_l^{|m|}(\cos\theta) \times \sqrt{\frac{1}{2\pi}} \exp(im\phi)$$

$$L_{n+l}^{2l+1}(\rho) = (-1)^{n+l} \frac{(n+l)!}{(n-l-1)!} \left\{ \rho^{(n-l-1)} - \frac{(n+l-1)}{1!} \rho^{n+l-2} + \frac{(n+l)(n+l-1)(n-l-1)(n-l-2)}{2!} \rho^{n+l-3} \right\}$$

$$P_l^{|m|}(z) = \frac{(1-z^2)^{\frac{|m|}{2}}}{2^l l!} \frac{d^{l+|m|}}{dz^{l+|m|}} (z^2 - 1)^l$$

$$n = 1, 2, 3, \dots \geq l + 1$$

$$l = 0, 1, 2, \dots \geq |m|$$

$$m = 0, \pm 1, \pm 2, \dots$$

$$a_0 = \frac{4\pi\epsilon_0 \hbar^2}{m_e e^2}$$

; principal q. n.
; azimuthal q. n.
; magnetic q.n.
quantum numbers

; associated Legendre polynomials

; associated Laguerre polynomials

$$\varphi_{n,l,m}(r, \theta, \phi) = R(r)\Theta(\theta)\Phi(\phi)$$

$$R(r) = -\sqrt{\left(\frac{2}{na_0}\right)^3 \frac{(n-l-1)!}{2n\{(n+l)!\}^3}} \left(\frac{2r}{na_0}\right)^l \exp\left(-\frac{r}{na_0}\right) L_{n+l}^{2l+1}\left(\frac{r}{na_0}\right)$$

$$\Theta(\theta) = \sqrt{\frac{2l+1}{2} \frac{(l-|m|)!}{(l+|m|)!}} P_l^{|m|}(\cos\theta)$$

$$\Phi(\phi) = \sqrt{\frac{1}{2\pi}} \exp(im\phi)$$

$$E_n = -\frac{me^4}{2\hbar^2 (4\pi\epsilon_0)^2} \left(\frac{1}{n}\right)^2$$

$$n_{\text{electron density}} = \varphi_{n,l,m}^* \varphi_{n,l,m}$$

$$R(r) = -\sqrt{\left(\frac{2}{na_0}\right)^3 \frac{(n-l-1)!}{2n(n+l)!^3}} \left(\frac{2r}{na_0}\right)^l \exp\left(-\frac{r}{na_0}\right) L_{n+l}^{2l+1}\left(\frac{r}{na_0}\right)$$

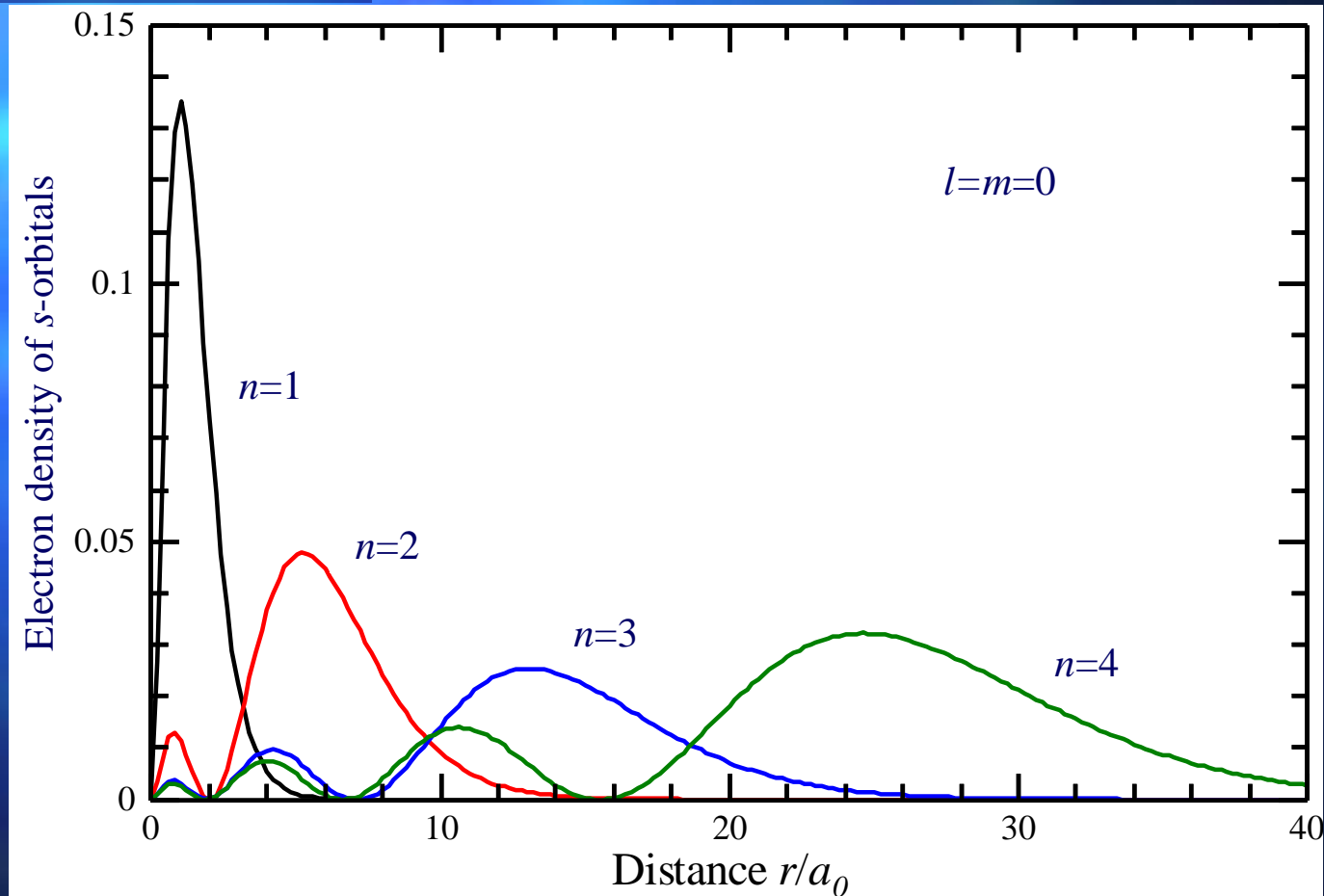

Spectral lines emitted from hydrogen plasma

- **Balmer series** (1885, Johann Jakob Balmer) $n = 2$ (Q: Why this is first ?)
- **Lyman series** (1906, Theodore Lyman) $n = 1$
- **Paschen series** (1908, Ritz Paschen) $n = 3$

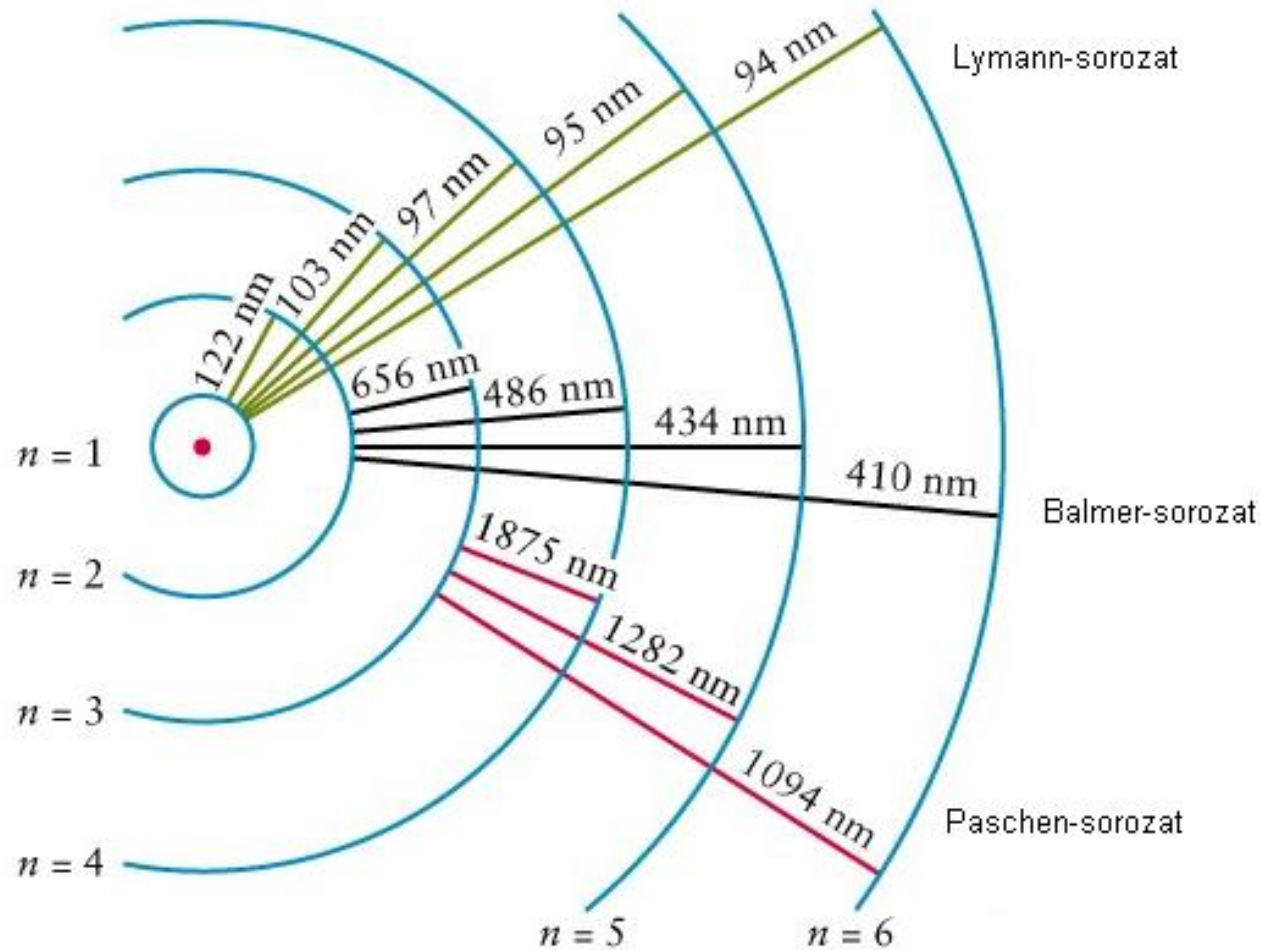

Spectral lines emitted from hydrogen plasma

- **Balmer series** (1885, Johann Jakob Balmer) $n = 2$
- **Lyman series** (1906, Theodore Lyman) $n = 1$
- **Paschen series** (1908, Ritz Paschen) $n = 3$

Rydberg formula for hydrogen

$$\frac{1}{\lambda} = R \left(\frac{1}{n_1^2} - \frac{1}{n_2^2} \right)$$

$$\begin{aligned} \frac{1}{\lambda} &= \frac{1}{hc} E_{\text{photon}} = \frac{1}{2\pi\hbar c} E_{\text{photon}} = \frac{1}{2\pi\hbar c} (E_{n_2} - E_{n_1}) \\ &= \frac{me^4}{8c(2\pi\hbar)^3 \epsilon_0^2} \left(\frac{1}{n_1^2} - \frac{1}{n_2^2} \right) \end{aligned}$$

$$E_n = -\frac{me^4}{2\hbar^2(4\pi\epsilon_0)^2} \left(\frac{1}{n} \right)^2$$

$$E_{\text{photon}} = h\nu = h \frac{c}{\lambda}$$

- **Brackett series** (1922) $n = 4$
- **Pfund series** (1924) $n = 5$
- **Humphreys series** (1953) $n = 6$

5. Isolated ionic core with one electron (1)

as a one electron and one ion system

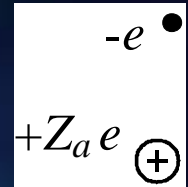

$$\mathbf{H}\varphi = E\varphi \quad \mathbf{H} = -\frac{\hbar^2}{2m}\nabla^2 - \frac{Z_a e^2}{4\pi\epsilon_0 r}$$

- Born-Oppenheimer approximation

$$\frac{1}{a_0} \rightarrow \frac{Z_a}{a_0}$$

$$\varphi_{n,l,m}(r, \theta, \phi) = R(r)\Theta(\theta)\Phi(\phi) \left\{ \begin{array}{l} R(r) = -\sqrt{\left(\frac{2Z_a}{na_0}\right)^3 \frac{(n-l-1)!}{2n!(n+l)!}} \left(\frac{2Z_a r}{na_0}\right)^l \exp\left(-\frac{Z_a r}{na_0}\right) L_{n+l}^{2l+1}\left(\frac{Z_a r}{na_0}\right) \\ \Theta(\theta) = \sqrt{\frac{2l+1}{2} \frac{(l-|m|)!}{(l+|m|)!}} P_l^{|m|}(\cos\theta) \\ \Phi(\phi) = \sqrt{\frac{1}{2\pi}} \exp(im\phi) \end{array} \right.$$

$$E_n = -\frac{me^4}{2\hbar^2(4\pi\epsilon_0)^2} \left(\frac{Z_a}{n}\right)^2$$

Extrapolation of "one ion - one electron model" to isolated other neutral atoms

Quantum number and periodic table

	<i>s</i>		<i>d</i>										<i>p</i>						
	1	2	1	2	3	4	5	6	7	8	9	10	1	2	3	4	5	6	
	IA	IIA	IIIA	IVA	VA	VIA	VIIA	VIII				IB	IIB	IIIB	IVB	VB	VIB	VIIB	0
1	H																		He
2	Li	Be											B	C	N	O	F	Ne	
3	Na	Mg											Al	Si	P	S	Cl	Ar	
4	K	Ca	Sc	Ti	V	Cr	Mn	Fe	Co	Ni	Cu	Zn	Ga	Ge	As	Se	Br	Kr	
5	Rb	Sr	Y	Zr	Nb	Mo	Tc	Ru	Rh	Pd	Ag	Cd	In	Sn	Sb	Te	I	Xe	
6	Cs	Ba	*	Hf	Ta	W	Re	Os	Ir	Pt	Au	Hg	Tl	Pb	Bi	Po	At	Rn	
7	Fr	Ra	**																
			<i>f</i>																
			1	2	3	4	5	6	7	8	9	10	11	12	13	14			
6	*		La	Ce	Pr	Nd	Pm	Sm	Eu	Gd	Tb	Dy	Ho	Er	Tm	Yb	Lu		
7	**		Ac	Th	Pa	U	Np	Pu	Am	Cm	Bk	Cf	Es	Fm	Md	No	Lr		

Order of occupation

Energy depends on only principal quantum number n

$$E_n = -\frac{m e^4}{2 \hbar^2 (4 \pi \epsilon_0)^2} \left(\frac{Z_a}{n} \right)^2$$

$$\mathbf{H} = -\frac{\hbar^2}{2m} \nabla^2 - \frac{1}{4 \pi \epsilon_0} \frac{Z_a e^2}{r_a}$$

Quantum numbers			Orbitals	Shell	
n	l	m			
1	0	0	1s	K	K
2	0	0	2s	L ₁	L
	1	0	2p	L ₂₃	
		± 1			
3	0	0	3s	M ₁	M
	1	0	3p	M ₂₃	
2	0	3d	M ₄₅		
				± 1	
				± 2	
4	0	0	4s	N ₁	N
	1	0	4p	N ₂₃	
	2	0	4d	N ₄₅	
		± 2			
3	0	4f	N ₆₇		
				± 1	
				± 2	
		± 3			
5	0	0	5s	O ₁	O
	1	0	5p	O ₂₃	
2	0	5d	O ₄₅		
				± 1	
				± 2	
		± 3			
		
6	0	0	6s	P ₁	P

Extrapolation of "one ion - one electron model" to isolated other neutral atoms

- Order of occupation
considering electron-electron interaction

$$\mathbf{H} = -\frac{\hbar^2}{2m} \sum_{i=1}^N \nabla_i^2 - \frac{1}{4\pi\epsilon_0} \left(\sum_{i=1}^N \frac{Z_a e^2}{r_{a,i}} - \sum_{\substack{i,j=1 \\ (i>j)}}^N \frac{e^2}{R_{e,i,j}} \right)$$

$$= \sum_{i=1}^N \left(-\frac{\hbar^2}{2m} \nabla_i^2 - \frac{1}{4\pi\epsilon_0} \frac{Z_a e^2}{r_{a,i}} \right) - \frac{1}{4\pi\epsilon_0} \sum_{\substack{i,j=1 \\ (i>j)}}^N \frac{e^2}{R_{e,i,j}}$$



$$\mathbf{H} = -\frac{\hbar^2}{2m} \nabla^2 - \frac{1}{4\pi\epsilon_0} \frac{Z_a e^2}{r_a}$$

$$E_n = -\frac{m e^4}{2\hbar^2 (4\pi\epsilon_0)^2} \left(\frac{Z_a}{n} \right)^2$$

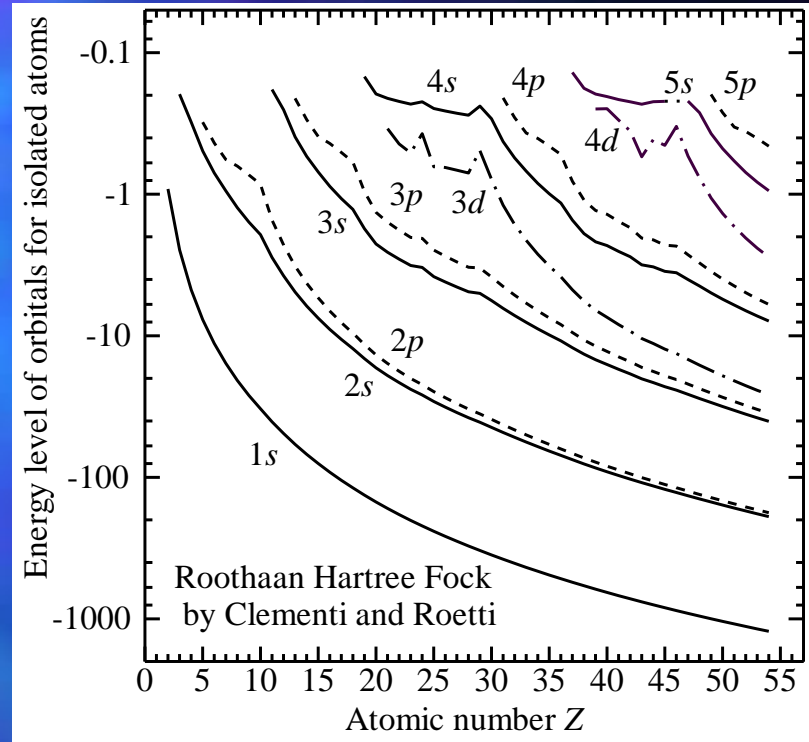

	<i>s</i>		<i>d</i>								<i>p</i>							
	1	2	1	2	3	4	5	6	7	8	9	10	1	2	3	4	5	6
	IA	IIA	IIIA	IVA	VA	VIA	VIIA	VIII			IB	IIB	IIIB	IVB	VB	VIB	BIIB	0
1	H																	He
2	Li	Be											B	C	N	O	F	Ne
3	Na	Mg											Al	Si	P	S	Cl	Ar
4	K	Ca	Sc	Ti	V	Cr	Mn	Fe	Co	Ni	Cu	Zn	Ga	Ge	As	Se	Br	Kr
5	Rb	Sr	Y	Zr	Nb	Mo	Tc	Ru	Rh	Pd	Ag	Cd	In	Sn	Sb	Te	I	Xe
6	Cs	Ba	*	Hf	Ta	W	Re	Os	Ir	Pt	Au	Hg	Tl	Pb	Bi	Po	At	Rn
7	Fr	Ra	**															
				<i>f</i>														
				1	2	3	4	5	6	7	8	9	10	11	12	13	14	
6	*			La	Ce	Pr	Nd	Pm	Sm	Eu	Gd	Tb	Dy	Ho	Er	Tm	Yb	Lu
7	**			Ac	Th	Pa	U	Np	Pu	Am	Cm	Bk	Cf	Es	Fm	Md	No	Lr

Electron configuration for neutral isolated atoms

Shell	K		L			M			N				O				P			Q				
Principal Q.N.	1		2			3			4				5				6			7				
Azimuthal Q.N.	0		0	1		0	1	2		0	1	2		3	0	1	2		0					
Orbitals	1s		2s	2p		3s	3p	3d		4s	4p	4d		4f	5s	5p	5d		5f	6s	6p	6d		7s
L.	Z																							
1	1	H	1																					
	2	He	2																					
2	3	Li	2	1																				
	4	Be	2	2																				
	5	B	2	2	1																			
	6	C	2	2	2																			
	7	N	2	2	3																			
	8	O	2	2	4																			
	9	F	2	2	5																			
	10	Ne	2	2	6																			
3	11	Na	2	2	6	1																		
	12	Mg	2	2	6	2																		
	13	Al	2	2	6	2	1																	
	14	Si	2	2	6	2	2																	
	15	P	2	2	6	2	3																	
	16	S	2	2	6	2	4																	
	17	Cl	2	2	6	2	5																	
	18	Ar	2	2	6	2	6																	
4	19	K	2	2	6	2	6	1																
	20	Ca	2	2	6	2	6	2																
	21	Sc	2	2	6	2	6	1	2															
	22	Ti	2	2	6	2	6	2	2															
	23	V	2	2	6	2	6	3	2															
	24	Cr	2	2	6	2	6	5	1															
	25	Mn	2	2	6	2	6	5	2															
	26	Fe	2	2	6	2	6	6	2															
	27	Co	2	2	6	2	6	7	2															
	28	Ni	2	2	6	2	6	8	2															
	29	Cu	2	2	6	2	6	10	1															
	30	Zn	2	2	6	2	6	10	2															
	31	Ga	2	2	6	2	6	10	2	1														
	32	Ge	2	2	6	2	6	10	2	2														
	33	As	2	2	6	2	6	10	2	3														
	34	Se	2	2	6	2	6	10	2	4														
	35	Br	2	2	6	2	6	10	2	5														
	36	Kr	2	2	6	2	6	10	2	6														
5	37	Rb	2	2	6	2	6	10	2	6														
	...																							

	s		d										p							
	1	2	1	2	3	4	5	6	7	8	9	10	1	2	3	4	5	6		
	IA	IIA	IIIA	IVA	VA	VIA	VIIA	VIII				IB	IIB	IIIB	IVB	VB	VIB	BIIB	0	
1	H																		He	
2	Li	Be												B	C	N	O	F	Ne	
3	Na	Mg												Al	Si	P	S	Cl	Ar	
4	K	Ca	Sc	Ti	V	Cr	Mn	Fe	Co	Ni	Cu	Zn		Ga	Ge	As	Se	Br	Kr	
5	Rb	Sr	Y	Zr	Nb	Mo	Tc	Ru	Rh	Pd	Ag	Cd		In	Sn	Sb	Te	I	Xe	
6	Cs	Ba	*	Hf	Ta	W	Re	Os	Ir	Pt	Au	Hg		Tl	Pb	Bi	Po	At	Rn	
7	Fr	Ra	**																	
			f																	
			1	2	3	4	5	6	7	8	9	10	11	12	13	14				
6	*		La	Ce	Pr	Nd	Pm	Sm	Eu	Gd	Tb	Dy	Ho	Er	Tm	Yb	Lu			
7	**		Ac	Th	Pa	U	Np	Pu	Am	Cm	Bk	Cf	Es	Fm	Md	No	Lr			

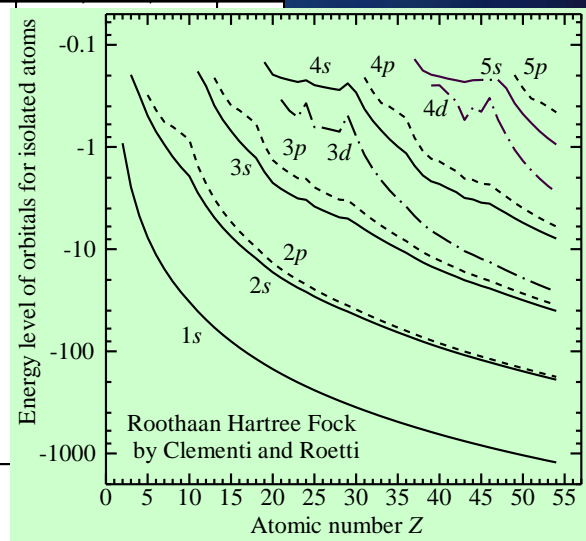

	<i>s</i>		<i>d</i>										<i>p</i>					
	1	2	1	2	3	4	5	6	7	8	9	10	1	2	3	4	5	6
	IA	IIA	IIIA	IVA	VA	VIA	VIIA	VIII			IB	IIB	IIIB	IVB	VB	VIB	VIIB	0
1	H																	He
2	Li	Be											B	C	N	O	F	Ne
3	Na	Mg											Al	Si	P	S	Cl	Ar
4	K	Ca	Sc	Ti	V	Cr	Mn	Fe	Co	Ni	Cu	Zn	Ga	Ge	As	Se	Br	Kr
5	Rb	Sr	Y	Zr	Nb	Mo	Tc	Ru	Rh	Pd	Ag	Cd	In	Sn	Sb	Te	I	Xe
6	Cs	Ba	*	Hf	Ta	W	Re	Os	Ir	Pt	Au	Hg	Tl	Pb	Bi	Po	At	Rn
7	Fr	Ra	**															
				<i>f</i>														
				1	2	3	4	5	6	7	8	9	10	11	12	13	14	
6	*			La	Ce	Pr	Nd	Pm	Sm	Eu	Gd	Tb	Dy	Ho	Er	Tm	Yb	Lu
7	**			Ac	Th	Pa	U	Np	Pu	Am	Cm	Bk	Cf	Es	Fm	Md	No	Lr

Shell	K	L	M			N				O			P			Q		
Principal Q.N.	1	2	3			4				5			6			7		
Azimuthal Q.N.	0	0	1	2	3	0	1	2	3	0	1	2	3	0	1	2	0	
Orbitals	1s	2s	2p	3s	3p	3d	4s	4p	4d	4f	5s	5p	5d	5f	6s	6p	6d	7s
L.	Z																	
...	36	Kr	2	2	6	2	6	10	2	6								
5	37	Rb	2	2	6	2	6	10	2	6				1				
	38	Sr	2	2	6	2	6	10	2	6				2				
	39	Y	2	2	6	2	6	10	2	6	1			2				
	40	Zr	2	2	6	2	6	10	2	6	2			2				
	41	Nb	2	2	6	2	6	10	2	6	4			1				
	42	Mo	2	2	6	2	6	10	2	6	5			1				
	43	Tc	2	2	6	2	6	10	2	6	5			2				
	44	Ru	2	2	6	2	6	10	2	6	7			1				
	45	Rh	2	2	6	2	6	10	2	6	8			1				
	46	Pd	2	2	6	2	6	10	2	6	10							
	47	Ag	2	2	6	2	6	10	2	6	10			1				
	48	Cd	2	2	6	2	6	10	2	6	10			2				
	49	In	2	2	6	2	6	10	2	6	10				1			
	50	Sn	2	2	6	2	6	10	2	6	10				2		1	
	51	Sb	2	2	6	2	6	10	2	6	10				2		3	
	52	Te	2	2	6	2	6	10	2	6	10				2		4	
	53	I	2	2	6	2	6	10	2	6	10				2		5	
	54	Xe	2	2	6	2	6	10	2	6	10				2		6	
6	55	Cs	2	2	6	2	6	10	2	6	10				2	6		
...																		

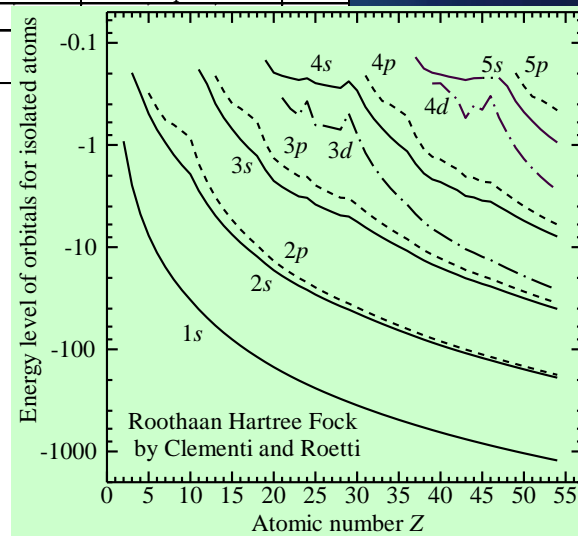

Shell		K	L	M			N				O				P			Q	
Principal Q.N.		1	2	3			4				5				6			7	
Azimuthal Q.N.		0	0	1	0	1	2	0	1	2	3	0	1	2	3	0	1	2	0
Orbitals		1s	2s	2p	3s	3p	3d	4s	4p	4d	4f	5s	5p	5d	5f	6s	6p	6d	7s
L.	Z																		
	... 54	Xe	2	2	6	2	6	10	2	6	10	2	6						
6	55	Cs	2	2	6	2	6	10	2	6	10	2	6		1				
	56	Ba	2	2	6	2	6	10	2	6	10	2	6		2				
	57	La	2	2	6	2	6	10	2	6	10	2	6	1		2			
	58	Ce	2	2	6	2	6	10	2	6	10	1	2	6	1	2			
	59	Pr	2	2	6	2	6	10	2	6	10	3	2	6		2			
	60	Nd	2	2	6	2	6	10	2	6	10	4	2	6		2			
	61	Pm	2	2	6	2	6	10	2	6	10	5	2	6		2			
	62	Sm	2	2	6	2	6	10	2	6	10	6	2	6		2			
	63	Eu	2	2	6	2	6	10	2	6	10	7	2	6		2			
	64	Gd	2	2	6	2	6	10	2	6	10	7	2	6	1	2			
	65	Tb	2	2	6	2	6	10	2	6	10	9	2	6		2			
	66	Dy	2	2	6	2	6	10	2	6	10	10	2	6		2			
	67	Ho	2	2	6	2	6	10	2	6	10	11	2	6		2			
	68	Er	2	2	6	2	6	10	2	6	10	12	2	6		2			
	69	Tm	2	2	6	2	6	10	2	6	10	13	2	6		2			
	70	Yb	2	2	6	2	6	10	2	6	10	14	2	6		2			
	71	Lu	2	2	6	2	6	10	2	6	10	14	2	6	1	2			
			2	2	6	2	6	10	2	6	10	14	2	6	2	2			
			2	2	6	2	6	10	2	6	10	14	2	6	3	2			
			2	2	6	2	6	10	2	6	10	14	2	6	4	2			
			2	2	6	2	6	10	2	6	10	14	2	6	5	2			

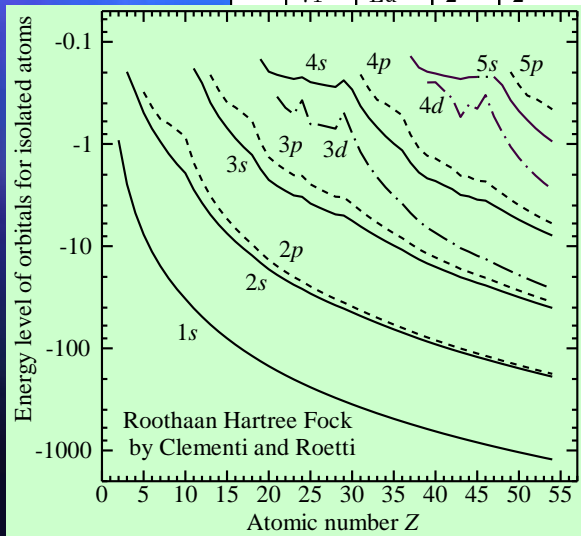

	<i>s</i>		<i>d</i>										<i>p</i>							
	1	2	1	2	3	4	5	6	7	8	9	10	1	2	3	4	5	6		
	IA	IIA	IIIA	IVA	VA	VIA	VIIA	VIII			IB	IIB	IIIB	IVB	VB	VIB	BIIB	0		
1	H																	He		
2	Li	Be													B	C	N	O	F	Ne
3	Na	Mg											Al	Si	P	S	Cl	Ar		
4	K	Ca	Sc	Ti	V	Cr	Mn	Fe	Co	Ni	Cu	Zn	Ga	Ge	As	Se	Br	Kr		
5	Rb	Sr	Y	Zr	Nb	Mo	Tc	Ru	Rh	Pd	Ag	Cd	In	Sn	Sb	Te	I	Xe		
6	Cs	Ba	*	Hf	Ta	W	Re	Os	Ir	Pt	Au	Hg	Tl	Pb	Bi	Po	At	Rn		
7	Fr	Ra	**																	
			<i>f</i>																	
			1	2	3	4	5	6	7	8	9	10	11	12	13	14				
6	*		La	Ce	Pr	Nd	Pm	Sm	Eu	Gd	Tb	Dy	Ho	Er	Tm	Yb	Lu			
7	**		Ac	Th	Pa	U	Np	Pu	Am	Cm	Bk	Cf	Es	Fm	Md	No	Lr			

	<i>s</i>		<i>d</i>								<i>p</i>								
	1	2	1	2	3	4	5	6	7	8	9	10	1	2	3	4	5	6	
	IA	IIA	IIIA	IVA	VA	VIA	VIIA	VIII				IB	IIB	IIIB	IVB	VB	VIB	VIIB	0
1	H																	He	
2	Li	Be											B	C	N	O	F	Ne	
3	Na	Mg											Al	Si	P	S	Cl	Ar	
4	K	Ca	Sc	Ti	V	Cr	Mn	Fe	Co	Ni	Cu	Zn	Ga	Ge	As	Se	Br	Kr	
5	Rb	Sr	Y	Zr	Nb	Mo	Tc	Ru	Rh	Pd	Ag	Cd	In	Sn	Sb	Te	I	Xe	
6	Cs	Ba	*	Hf	Ta	W	Re	Os	Ir	Pt	Au	Hg	Tl	Pb	Bi	Po	At	Rn	
7	Fr	Ra	**																
			<i>f</i>																
			1	2	3	4	5	6	7	8	9	10	11	12	13	14			
6	*		La	Ce	Pr	Nd	Pm	Sm	Eu	Gd	Tb	Dy	Ho	Er	Tm	Yb	Lu		
7	**		Ac	Th	Pa	U	Np	Pu	Am	Cm	Bk	Cf	Es	Fm	Md	No	Lr		

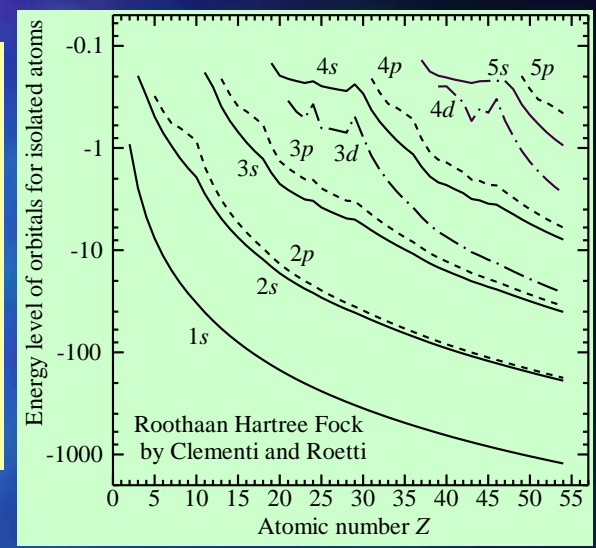

Shell		K	L			M				N				O				P	Q			
Principal Q.N.		1	2			3				4				5				6		7		
Azimuthal Q.N.		0	0	1		0	1	2		0	1	2	3		0	1	2	0				
Orbitals		1s	2s	2p		3s	3p	3d		4s	4p	4d	4f		5s	5p	5d	5f	6s	6p	6d	7s
L.	Z																					
	...																					
	86	Rn	2	2	6	2	6	10	2	6	10	14	2	6	10	2	6		2	6		1
7	87	Fr	2	2	6	2	6	10	2	6	10	14	2	6	10	2	6	10	2	6		2
	88	Ra	2	2	6	2	6	10	2	6	10	14	2	6	10	2	6	10	2	6		2
	89	Ac	2	2	6	2	6	10	2	6	10	14	2	6	10	2	6	10	2	6	1	2
	90	Th	2	2	6	2	6	10	2	6	10	14	2	6	10	2	6	10	2	6	2	2
	91	Pa	2	2	6	2	6	10	2	6	10	14	2	6	10	2	6	10	2	6	1	2
	92	U	2	2	6	2	6	10	2	6	10	14	2	6	10	2	6	10	2	6	1	2
	93	Np	2	2	6	2	6	10	2	6	10	14	2	6	10	2	6	10	2	6	1	2
	94	Pu	2	2	6	2	6	10	2	6	10	14	2	6	10	2	6	10	2	6		2
	95	Am	2	2	6	2	6	10	2	6	10	14	2	6	10	2	6	10	2	6		2
	96	Cm	2	2	6	2	6	10	2	6	10	14	2	6	10	2	6	10	2	6	1	2
	97	Bk	2	2	6	2	6	10	2	6	10	14	2	6	10	2	6	10	2	6		2
	98	Cf	2	2	6	2	6	10	2	6	10	14	2	6	10	2	6	10	2	6		2
	99	Es	2	2	6	2	6	10	2	6	10	14	2	6	10	2	6	10	2	6		2
	100	Fm	2	2	6	2	6	10	2	6	10	14	2	6	10	2	6	10	2	6		2

Spectroscopic naming for orbitals

Principle of analyses

- Electron Probe Micro Analyzer (EPMA)
- Energy Dispersive X-ray Spectroscopy (EDS)
- X-ray Photo-electron Spectroscopy (XPS)
- Auger Electron Spectroscopy (AES)

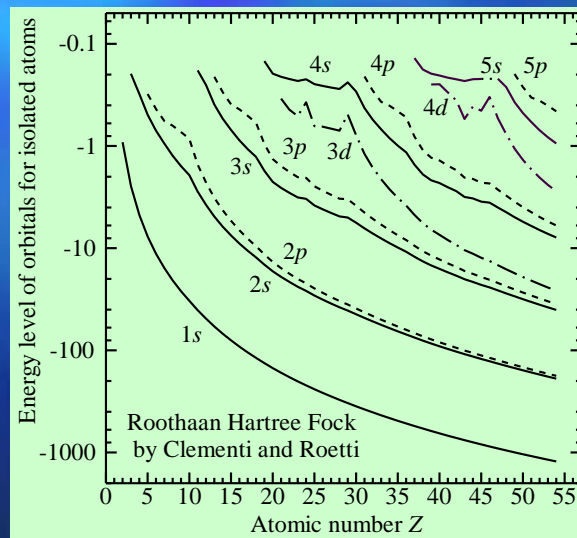

Quantum numbers			Orbitals	Shell	
n	l	m			
1	0	0	1s	K	K
2	0	0	2s	L ₁	L
	1	0 ±1	2p	L ₂₃	
3	0	0	3s	M ₁	M
	1	0 ±1	3p	M ₂₃	
	2	0 ±1 ±2	3d	M ₄₅	
4	0	0	4s	N ₁	N
	1	0 ±1	4p	N ₂₃	
	2	0 ±1 ±2	4d	N ₄₅	
		3	0 ±1 ±2 ±3	4f	
5	0	0	5s	O ₁	O
	1	0 ±1	5p	O ₂₃	
	2	0 ±1 ±2	5d	O ₄₅	
...
6	0	0	6s	P ₁	P
...
...

- **Electron Probe Micro Analyzer (EPMA)**
- **Energy Dispersive X-ray Spectroscopy (EDS)**
Secondary Electron Microscope (SEM)
- **X-ray Photo-electron Spectroscopy (XPS)**
= **Electron Spectroscopy for Chemical Analysis (ESCA)**
Hemispherical Electrostatic Analyzer (HEA)
Ultra High Vacuum (UHV) and Introduction chamber
Ion sputtering
- **Auger Electron Spectroscopy (AES)**
Secondary Electron Microscope (SEM)
Cylindrical Mirror Analyzer (CMA) or HEA
Ultra High Vacuum (UHV) and Introduction chamber
Ion sputtering



AES : Perkin Elmer PHI Model 650

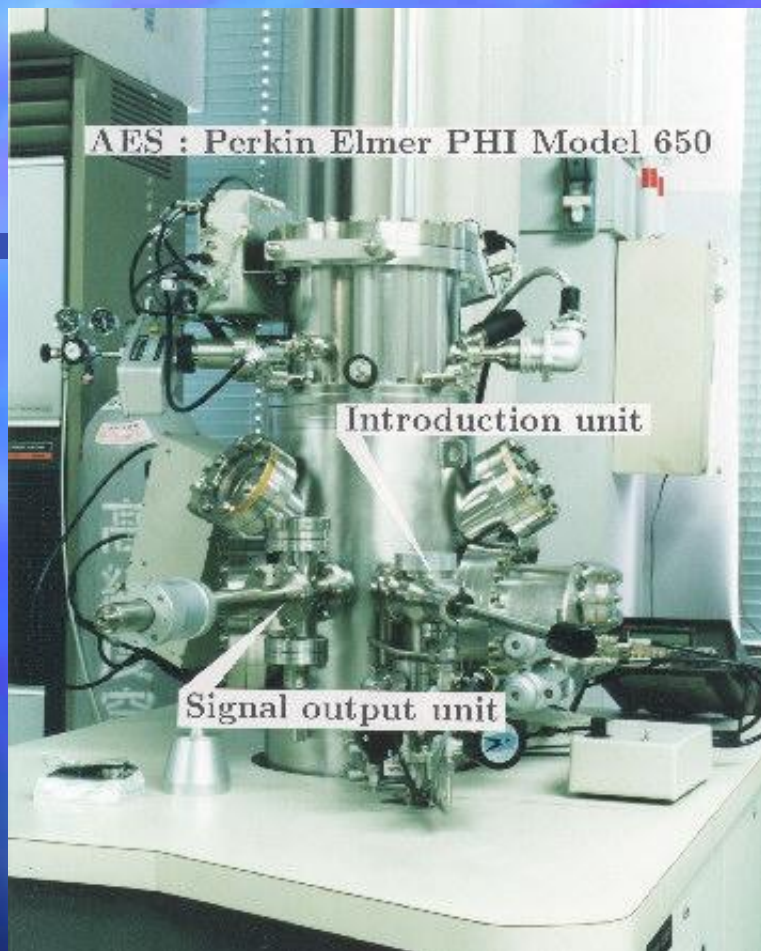

JPS-9200



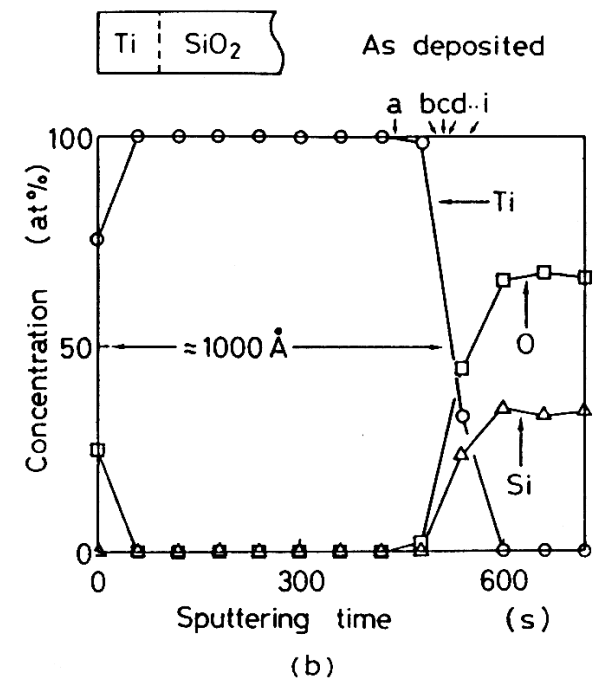
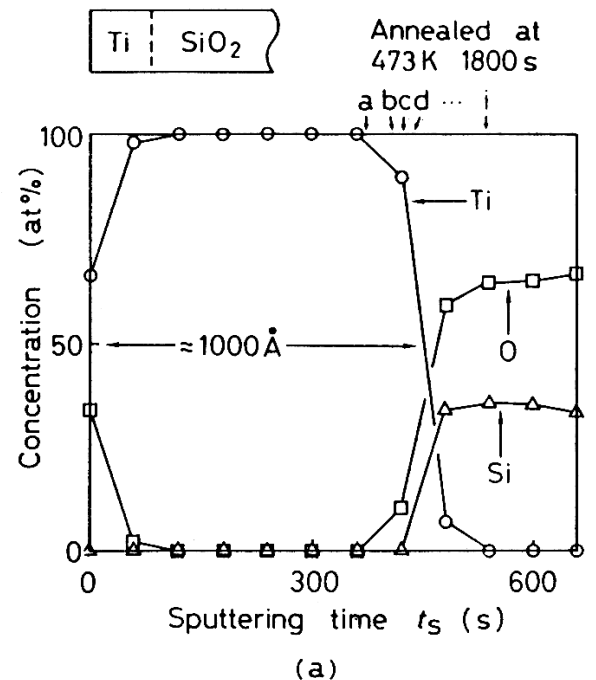
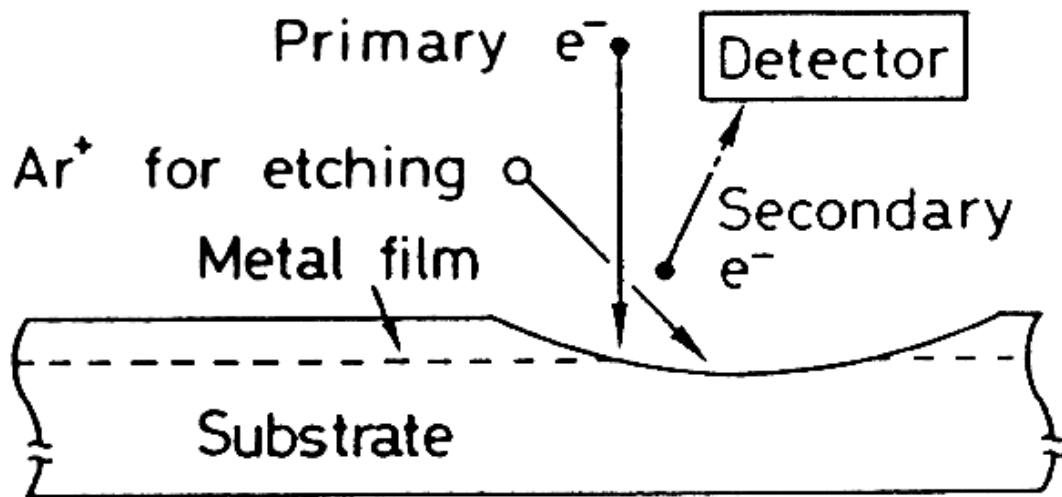
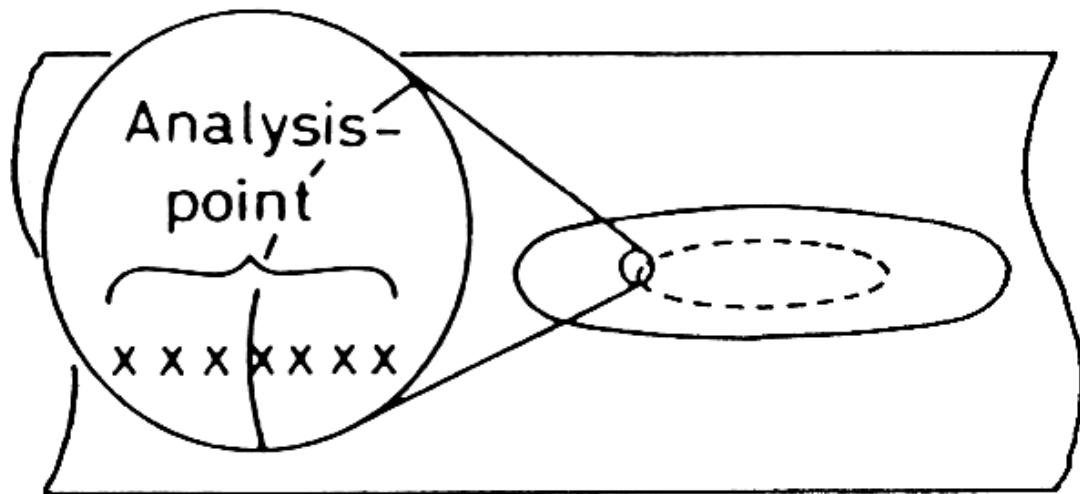

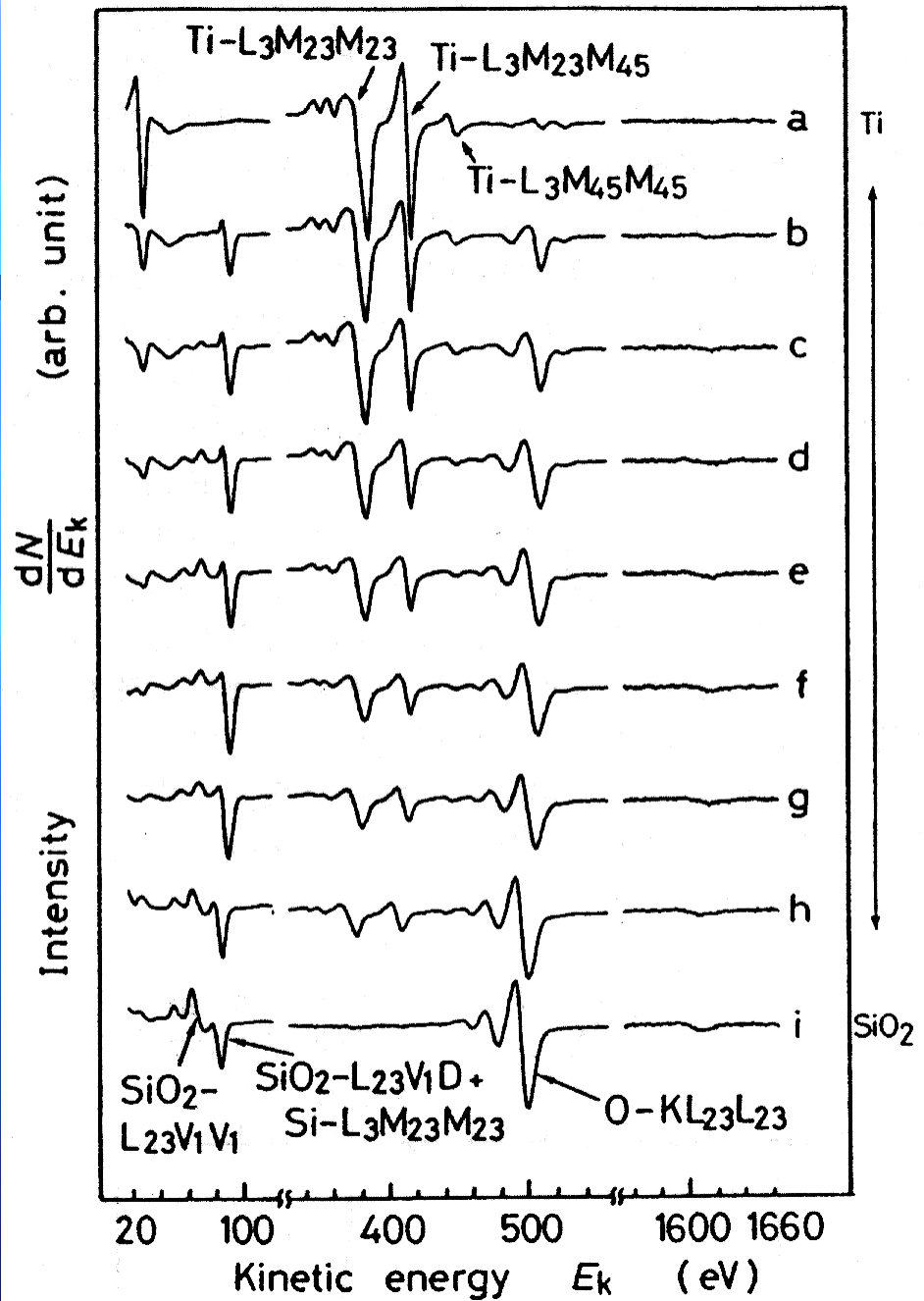

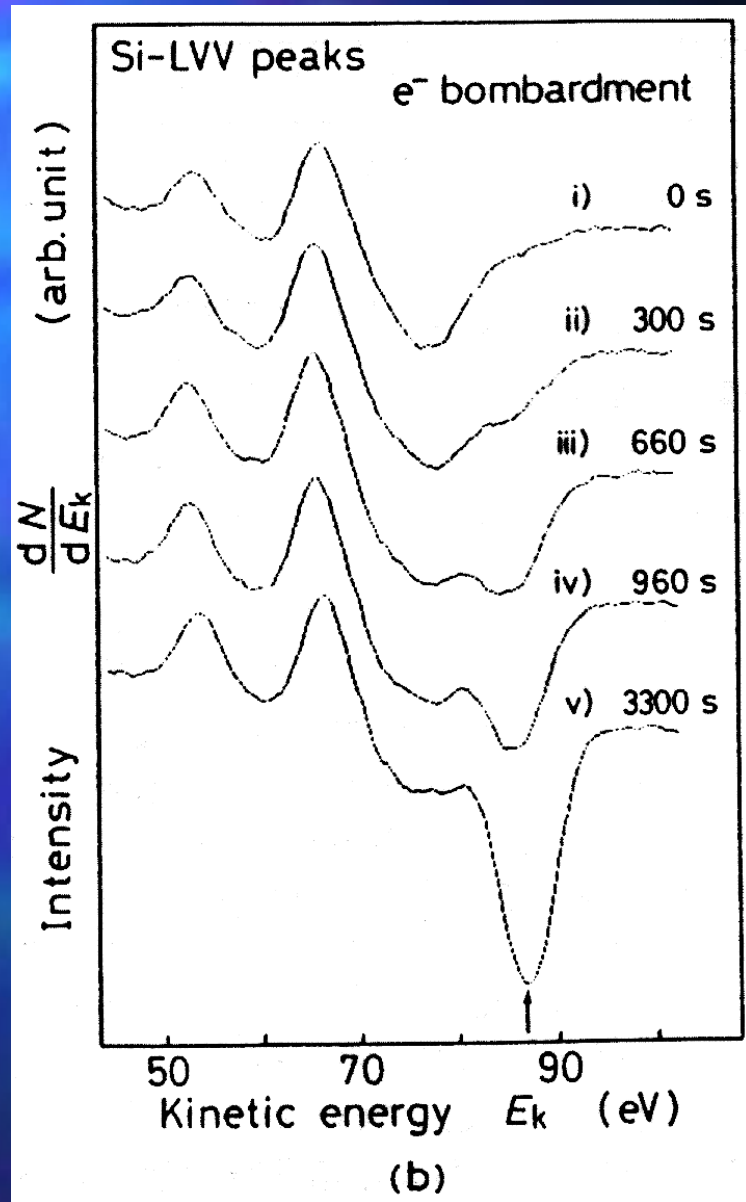
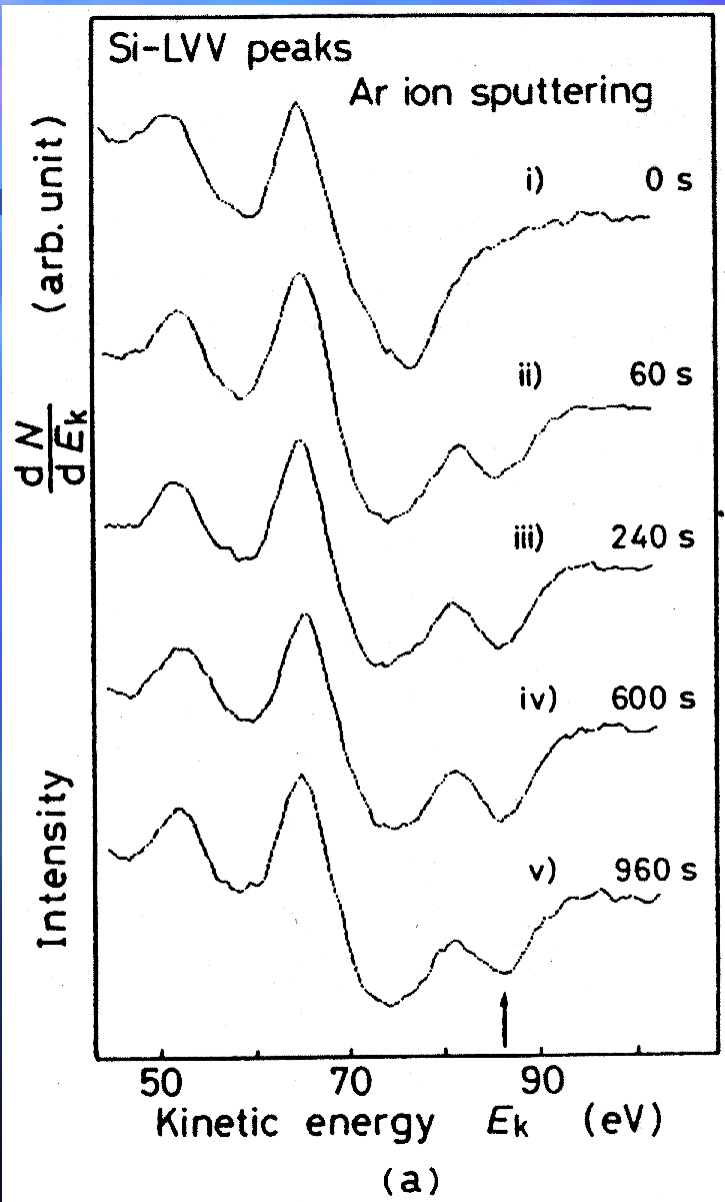

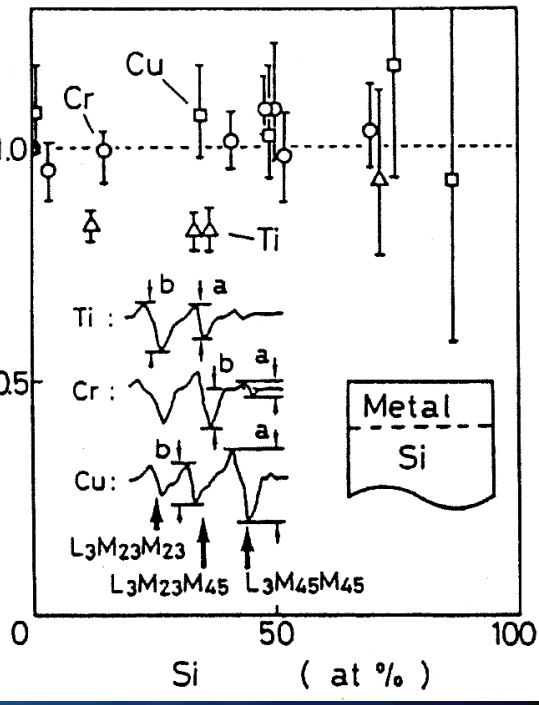
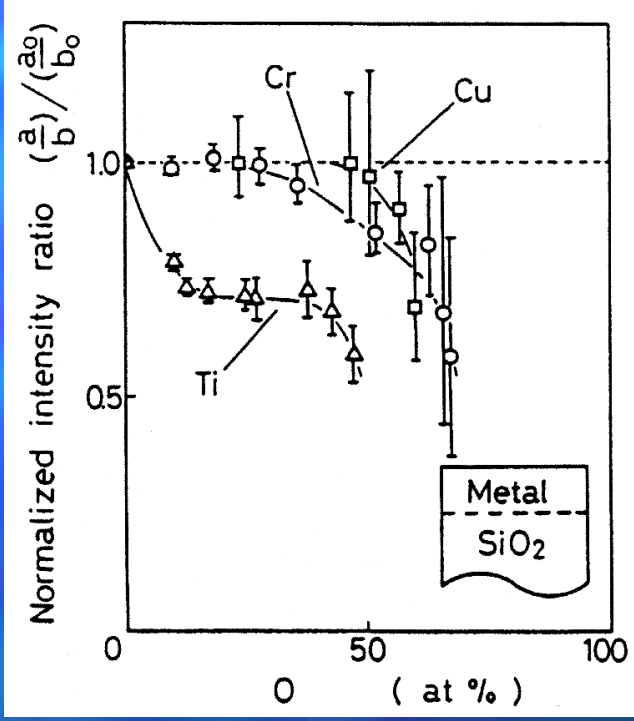
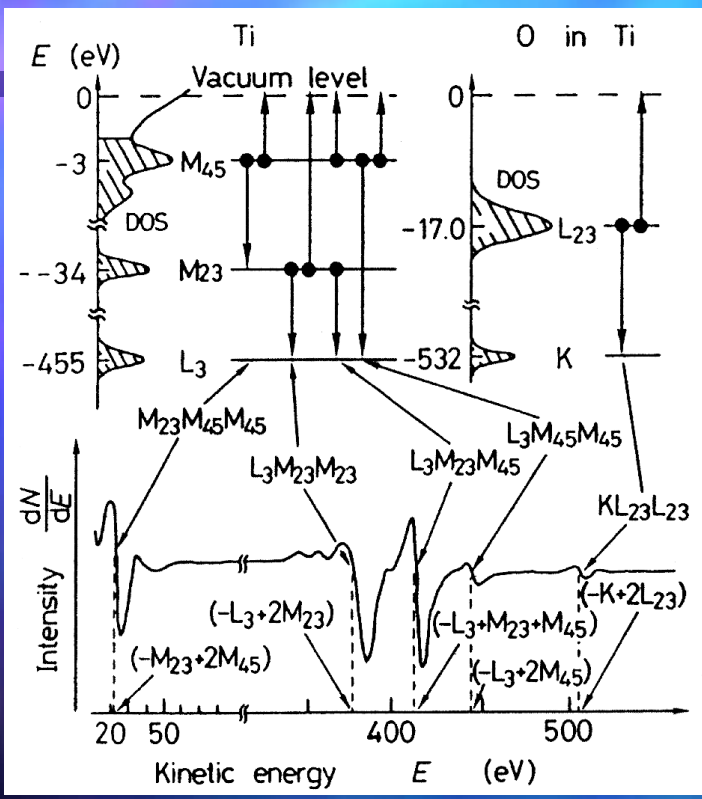

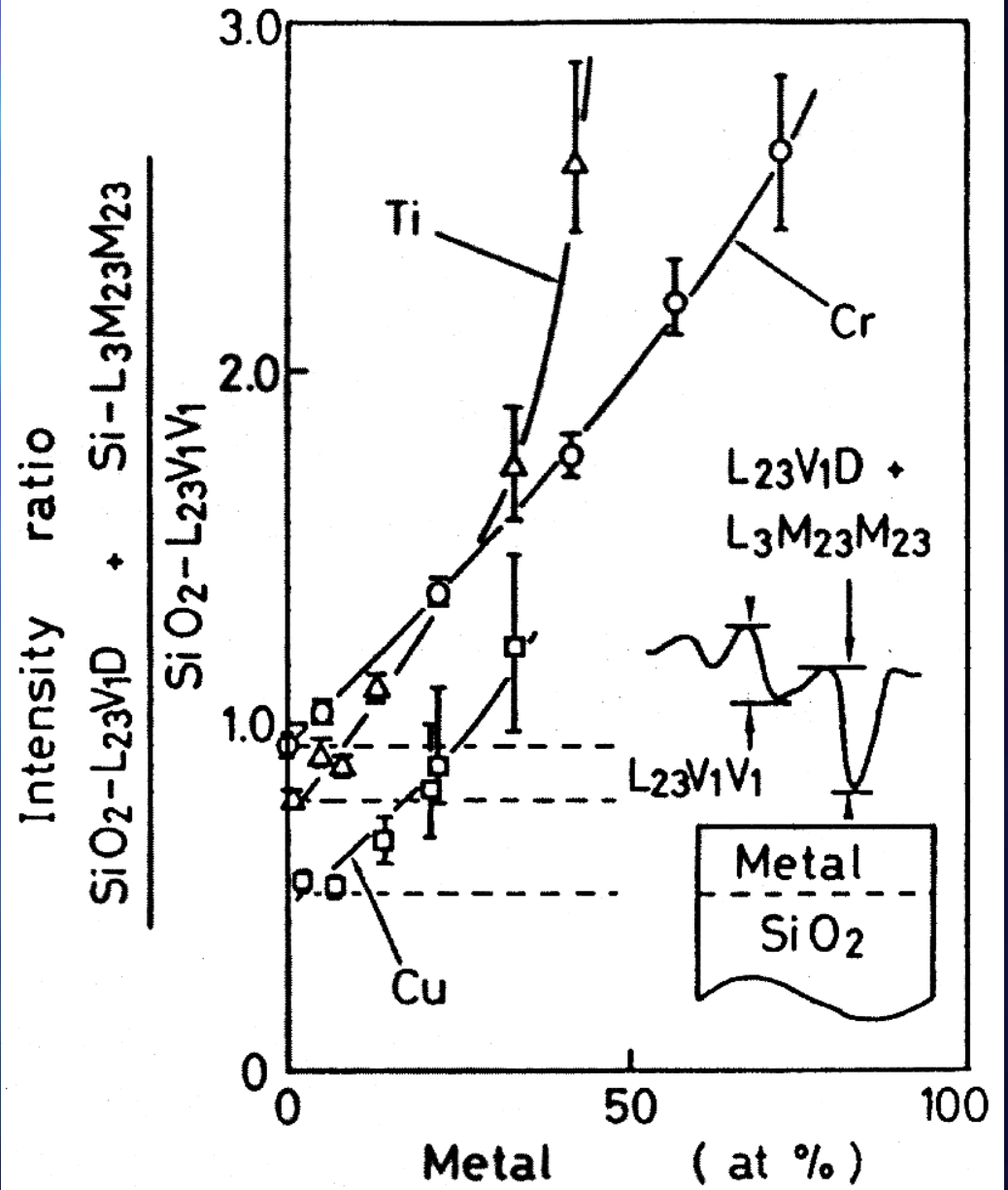
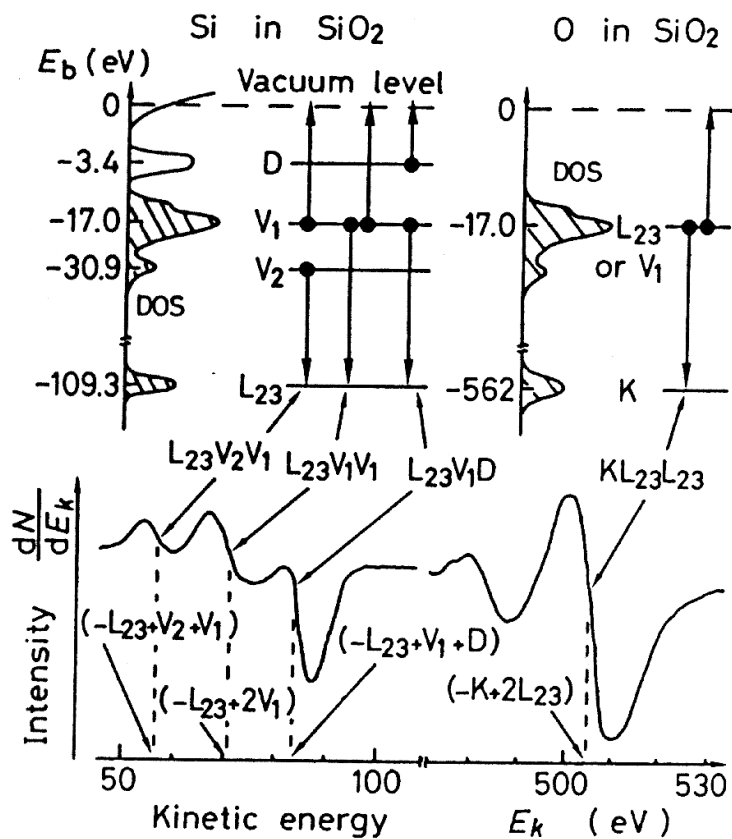
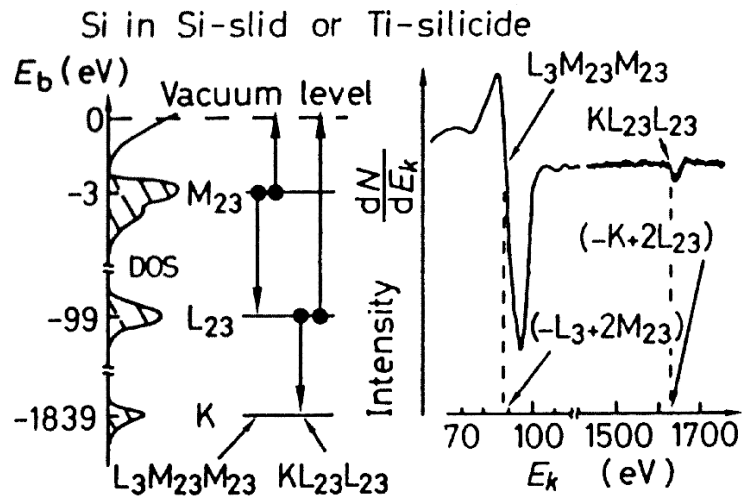

Chemical properties

- **Atomic radius**
 - Ionic radius
 - Covalent radius
 - Metallic radius
 - Van der Waars radius

- **Ionization energy**
(Work function)

- **Electro negativity**
 - Pauling
 - Mulliken
 - Etc...

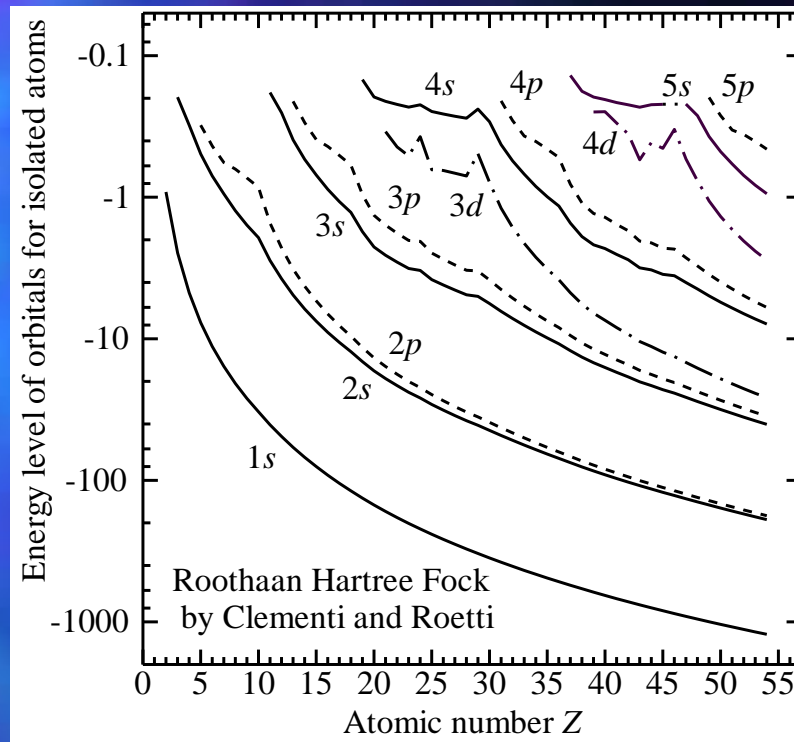

	<i>s</i>		<i>d</i>										<i>p</i>						
	1	2	1	2	3	4	5	6	7	8	9	10	1	2	3	4	5	6	
	IA	IIA	IIIA	IVA	VA	VIA	VIIA	VIII				IB	IIB	IIIB	IVB	VB	VIB	BIIB	0
1	H																		He
2	Li	Be											B	C	N	O	F		Ne
3	Na	Mg											Al	Si	P	S	Cl		Ar
4	K	Ca	Sc	Ti	V	Cr	Mn	Fe	Co	Ni	Cu	Zn	Ga	Ge	As	Se	Br		Kr
5	Rb	Sr	Y	Zr	Nb	Mo	Tc	Ru	Rh	Pd	Ag	Cd	In	Sn	Sb	Te	I		Xe
6	Cs	Ba	*	Hf	Ta	W	Re	Os	Ir	Pt	Au	Hg	Tl	Pb	Bi	Po	At		Rn
7	Fr	Ra	**																
				<i>f</i>															
				1	2	3	4	5	6	7	8	9	10	11	12	13	14		
6	*			La	Ce	Pr	Nd	Pm	Sm	Eu	Gd	Tb	Dy	Ho	Er	Tm	Yb		Lu
7	**			Ac	Th	Pa	U	Np	Pu	Am	Cm	Bk	Cf	Es	Fm	Md	No		Lr

→ Atomic radius decreases → Ionization energy increases → Electronegativity increases →

Group (vertical)	1	2	3	4	5	6	7	8	9	10	11	12	13	14	15	16	17	18
Period (horizontal)																		
1	H 2.20																	He
2	Li 0.98	Be 1.57											B 2.04	C 2.55	N 3.04	O 3.44	F 3.98	Ne
3	Na 0.93	Mg 1.31											Al 1.61	Si 1.90	P 2.19	S 2.58	Cl 3.16	Ar
4	K 0.82	Ca 1.00	Sc 1.36	Ti 1.54	V 1.63	Cr 1.66	Mn 1.55	Fe 1.83	Co 1.88	Ni 1.91	Cu 1.90	Zn 1.65	Ga 1.81	Ge 2.01	As 2.18	Se 2.55	Br 2.96	Kr 3.00
5	Rb 0.82	Sr 0.95	Y 1.22	Zr 1.33	Nb 1.6	Mo 2.16	Tc 1.9	Ru 2.2	Rh 2.28	Pd 2.20	Ag 1.93	Cd 1.69	In 1.78	Sn 1.96	Sb 2.05	Te 2.1	I 2.66	Xe 2.60
6	Cs 0.79	Ba 0.89	*	Hf 1.3	Ta 1.5	W 2.36	Re 1.9	Os 2.2	Ir 2.20	Pt 2.28	Au 2.54	Hg 2.00	Tl 1.62	Pb 2.33	Bi 2.02	Po 2.0	At 2.2	Rn 2.2
7	Fr 0.7	Ra 0.9	**	Rf	Db	Sg	Bh	Hs	Mt	Ds	Rg	Uub	Uut	Uuq	Uup	Uuh	Uus	Uuo
Lanthanides	*	La 1.1	Ce 1.12	Pr 1.13	Nd 1.14	Pm 1.13	Sm 1.17	Eu 1.2	Gd 1.2	Tb 1.1	Dy 1.22	Ho 1.23	Er 1.24	Tm 1.25	Yb 1.1	Lu 1.27		
Actinides	**	Ac 1.1	Th 1.3	Pa 1.5	U 1.38	Np 1.36	Pu 1.28	Am 1.13	Cm 1.28	Bk 1.3	Cf 1.3	Es 1.3	Fm 1.3	Md 1.3	No 1.3	Lr 1.291		

Periodic table of electronegativity using the Pauling scale

See also Periodic table

Do you have systematic feature of elements ?

Calculation by yourself is essential. Please try it.

Material which shows ...

- the highest melting point (or cohesive energy),
- larger electro-negativity (or smaller ionization energy),
- close-pack structure (fcc,hcp,bcc,sc,dia.,,,,),
- chemical activity (or non-activity)

	<i>s</i>		<i>d</i>								<i>p</i>									
	1	2	1	2	3	4	5	6	7	8	9	10	1	2	3	4	5	6		
	IA	IIA	IIIA	IVA	VA	VIA	VIIA	VIII				IB	IIIB	IVB	VB	VIB	VIIA		0	
1	H																			He
2	Li	Be											B	C	N	O	F		Ne	
3	Na	Mg											Al	Si	P	S	Cl		Ar	
4	K	Ca	Sc	Ti	V	Cr	Mn	Fe	Co	Ni	Cu	Zn	Ga	Ge	As	Se	Br	Kr		
5	Rb	Sr	Y	Zr	Nb	Mo	Tc	Ru	Rh	Pd	Ag	Cd	In	Sn	Sb	Te	I	Xe		
6	Cs	Ba	*	Hf	Ta	W	Re	Os	Ir	Pt	Au	Hg	Tl	Pb	Bi	Po	At	Rn		
7	Fr	Ra	**																	
			<i>f</i>																	
			1	2	3	4	5	6	7	8	9	10	11	12	13	14				
6	*		La	Ce	Pr	Nd	Pm	Sm	Eu	Gd	Tb	Dy	Ho	Er	Tm	Yb	Lu			
7	**		Ac	Th	Pa	U	Np	Pu	Am	Cm	Bk	Cf	Es	Fm	Md	No	Lr			

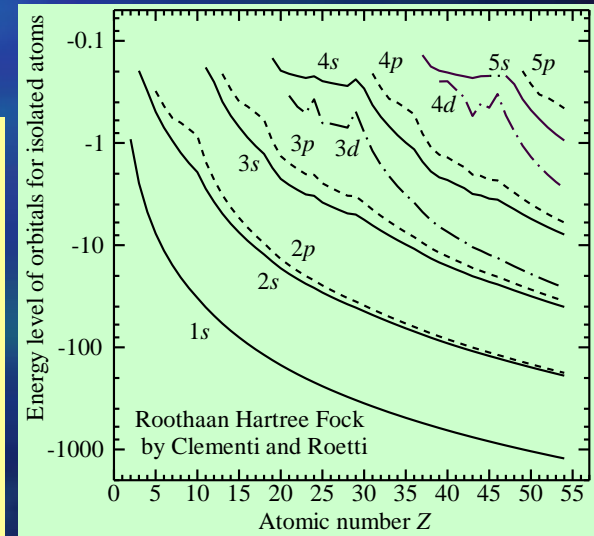

6. H_2^+

$$\mathbf{H}\varphi = E\varphi$$

$$\mathbf{H} = -\frac{\hbar^2}{2m}\nabla^2 - \frac{1}{4\pi\epsilon_0}\left(\frac{e^2}{r_a} + \frac{e^2}{r_b} - \frac{e^2}{R}\right)$$

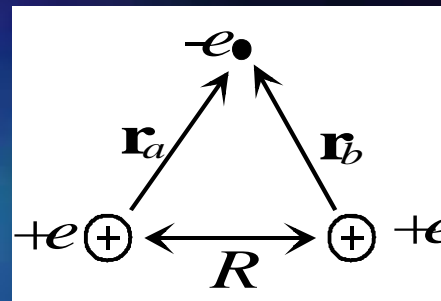

LCAO approximation

$$\varphi = C_a\chi_a + C_b\chi_b \quad \chi = \varphi_{1,0,0} \quad \int \varphi^2 d\tau = 1$$

$$E = \frac{\int \varphi \mathbf{H} \varphi d\tau}{\int \varphi \varphi d\tau} \rightarrow \min \quad \frac{\partial E}{\partial C_a} = \frac{\partial E}{\partial C_b} = 0$$

$$E = \frac{\int \varphi \mathbf{H} \varphi d\tau}{\int \varphi \varphi d\tau} = \frac{\int (C_a\chi_a + C_b\chi_b) \mathbf{H} (C_a\chi_a + C_b\chi_b) d\tau}{\int (C_a\chi_a + C_b\chi_b)^2 d\tau}$$

$$= \frac{C_a^2 \int \chi_a \mathbf{H} \chi_a d\tau + 2C_a C_b \int \chi_a \mathbf{H} \chi_b d\tau + C_b^2 \int \chi_b \mathbf{H} \chi_b d\tau}{C_a^2 + 2C_a C_b S + C_b^2}$$

$$= \frac{C_a^2 H_{aa} + 2C_a C_b H_{ab} + C_b^2 H_{bb}}{C_a^2 + 2C_a C_b S + C_b^2}$$



$$(C_a^2 + 2C_a C_b S + C_b^2)E - C_a^2 H_{aa} - 2C_a C_b H_{ab} - C_b^2 H_{bb} = 0$$

$$H_{aa} = \int \chi_a \mathbf{H} \chi_a d\tau$$

$$= \int \chi_a \left(-\frac{\hbar^2}{2m}\nabla^2 - \frac{e^2}{4\pi\epsilon_0 r_a} - \frac{e^2}{4\pi\epsilon_0 r_b} + \frac{e^2}{4\pi\epsilon_0 R} \right) \chi_a d\tau$$

$$= \int \chi_a \left(-\frac{\hbar^2}{2m}\nabla^2 - \frac{e^2}{4\pi\epsilon_0 r_a} \right) \chi_a d\tau$$

$$+ \int \chi_a \left(-\frac{e^2}{4\pi\epsilon_0 r_b} \right) \chi_a d\tau$$

$$+ \int \chi_a \left(-\frac{e^2}{4\pi\epsilon_0 R} \right) \chi_a d\tau$$

$$= E_{H-IS}$$

$$+ \int \chi_a \left(-\frac{e^2}{4\pi\epsilon_0 r_b} \right) \chi_a d\tau + \frac{e^2}{4\pi\epsilon_0 R}$$

$$= E_{H-IS} + J + \frac{e^2}{4\pi\epsilon_0 R}$$

$$J = \int \chi_a \left(-\frac{e^2}{4\pi\epsilon_0 r_b} \right) \chi_a d\tau$$

$$H_{bb} = E_{H-IS} + \int \chi_b \left(-\frac{e^2}{4\pi\epsilon_0 r_a} \right) \chi_b d\tau + \frac{e^2}{4\pi\epsilon_0 R}$$

$$= E_{H-IS} + J + \frac{e^2}{4\pi\epsilon_0 R}$$

$$H_{ab} = \int \chi_a \mathbf{H} \chi_b d\tau$$

$$= \int \chi_a \left(-\frac{\hbar^2}{2m} \nabla^2 - \frac{e^2}{4\pi\epsilon_0 r_a} - \frac{e^2}{4\pi\epsilon_0 r_b} + \frac{e^2}{4\pi\epsilon_0 R} \right) \chi_b d\tau$$

$$= \int \chi_a \left(-\frac{\hbar^2}{2m} \nabla^2 - \frac{e^2}{4\pi\epsilon_0 r_b} \right) \chi_b d\tau$$

$$+ \int \chi_a \left(-\frac{e^2}{4\pi\epsilon_0 r_a} \right) \chi_b d\tau$$

$$+ \int \chi_a \left(\frac{e^2}{4\pi\epsilon_0 R} \right) \chi_b d\tau$$

$$= E_{H-IS} \int \chi_a \chi_b d\tau$$

$$+ \int \chi_a \left(-\frac{e^2}{4\pi\epsilon_0 r_a} \right) \chi_b d\tau$$

$$+ \frac{e^2}{4\pi\epsilon_0 R} \int \chi_a \chi_b d\tau$$

$$= E_{H-IS} S + K + \frac{e^2}{4\pi\epsilon_0 R} S$$

$$K = \int \chi_a \left(-\frac{e^2}{4\pi\epsilon_0 r_a} \right) \chi_b d\tau$$

$$S = \int \chi_a \chi_b d\tau$$

$$J = \int \chi_a \left(-\frac{e^2}{4\pi\epsilon_0 r_b} \right) \chi_a d\tau$$

$$= -\frac{e^2}{4\pi\epsilon_0 R} \left\{ 1 - \left(1 + \frac{R}{a_0} \right) \exp\left(-\frac{2R}{a_0} \right) \right\}$$

$$K = \int \chi_a \left(-\frac{e^2}{4\pi\epsilon_0 r_a} \right) \chi_b d\tau$$

$$= -\frac{e^2}{4\pi\epsilon_0 a_0} \exp\left(-\frac{R}{a_0} \right) \left\{ 1 + \left(\frac{R}{a_0} \right) \right\}$$

$$S = \int \chi_a \chi_b d\tau$$

$$= \exp\left(-\frac{R}{a_0} \right) \left\{ 1 + \frac{R}{a_0} + \frac{1}{3} \left(\frac{R}{a_0} \right)^2 \right\}$$



$$\chi_a = \sqrt{\frac{1}{\pi a_0^3}} \exp\left(-\frac{r_a}{a_0} \right)$$

$$v = \frac{r_a - r_b}{R} \quad \mu = \frac{r_a + r_b}{R} \quad d\tau = \left(\frac{R}{2} \right)^3 (\mu^2 - v^2) d\mu dv d\varphi$$

$$\frac{\partial E}{\partial C_a} = \frac{\partial E}{\partial C_b} = 0$$

$$(C_a^2 + 2C_a C_b S + C_b^2)E - C_a^2 H_{aa} - 2C_a C_b H_{ab} - C_b^2 H_{bb} = 0$$

$$(E - H_{aa})C_a + (SE - H_{ab})C_b = 0$$

$$(E - H_{bb})C_b + (SE - H_{ab})C_a = 0$$

$$\begin{pmatrix} E - H_{aa} & SE - H_{ab} \\ SE - H_{ab} & E - H_{bb} \end{pmatrix} \begin{pmatrix} C_a \\ C_b \end{pmatrix} = 0$$

$$\begin{vmatrix} E - H_{aa} & SE - H_{ab} \\ SE - H_{ab} & E - H_{bb} \end{vmatrix} = (E - H_{aa})(E - H_{bb}) - (SE - H_{ab})^2 = 0$$

$$H_{aa} = H_{bb} \quad \int \varphi^2 dt = C_a^2 + 2C_a C_b S + C_b^2 = 1$$

$$(E - H_{aa} + SE - H_{ab})(E - H_{aa} - SE + H_{ab}) = 0$$

$$E = \begin{cases} H_{aa} - (SE - H_{ab}) \\ H_{aa} + (SE - H_{ab}) \end{cases}$$

$$2C_a^2 + 2C_a^2 S = 1$$

$$2C_a^2 - 2C_a^2 S = 1$$

$$C_a = \pm \frac{1}{\sqrt{2 - 2S}} = -C_b$$

$$C_a = \pm \frac{1}{\sqrt{2 + 2S}} = C_b$$

$$\varphi = \pm \frac{\chi_a + \chi_b}{\sqrt{2 + 2S}}$$

$$\varphi = \pm \frac{\chi_a - \chi_b}{\sqrt{2 - 2S}}$$

$$S = \exp\left(-\frac{R}{a_0}\right) \left[1 + \frac{R}{a_0} + \frac{1}{3} \left(\frac{R}{a_0}\right)^2 \right]$$

$$E = \begin{cases} E_{H-IS} + \frac{e^2}{4\pi\epsilon_0 R(1+S)} \exp\left(-\frac{R}{a_0}\right) \left[\left\{ 1 - \frac{2}{3} \left(\frac{R}{a_0}\right)^2 \right\} + \left\{ 1 + \frac{R}{a_0} \right\} \right] \exp\left(-\frac{R}{a_0}\right) \\ E_{H-IS} - \frac{e^2}{4\pi\epsilon_0 R(1-S)} \exp\left(-\frac{R}{a_0}\right) \left[\left\{ 1 - \frac{2}{3} \left(\frac{R}{a_0}\right)^2 \right\} - \left\{ 1 + \frac{R}{a_0} \right\} \right] \exp\left(-\frac{R}{a_0}\right) \end{cases}$$

$$E = \begin{cases} E_{H-1S} + \frac{e^2}{4\pi\epsilon_0 R(1+S)} \exp\left(-\frac{R}{a_0}\right) \left[\left\{ 1 - \frac{2}{3} \left(\frac{R}{a_0} \right)^2 \right\} + \left\{ 1 + \frac{R}{a_0} \right\} \right] \exp\left(-\frac{R}{a_0}\right) & : \quad \varphi = \pm \frac{\chi_a + \chi_b}{\sqrt{2+2S}} \quad : \text{ Bonding state} \\ E_{H-1S} - \frac{e^2}{4\pi\epsilon_0 R(1-S)} \exp\left(-\frac{R}{a_0}\right) \left[\left\{ 1 - \frac{2}{3} \left(\frac{R}{a_0} \right)^2 \right\} - \left\{ 1 + \frac{R}{a_0} \right\} \right] \exp\left(-\frac{R}{a_0}\right) & : \quad \varphi = \pm \frac{\chi_a - \chi_b}{\sqrt{2-2S}} \quad : \text{ Anti-bonding state} \end{cases}$$

$$a_0 = \frac{4\pi\epsilon_0 \hbar^2}{m_e e^2}$$

$$42.7 \times 2 = 85.4 \text{ kcal/mol}$$

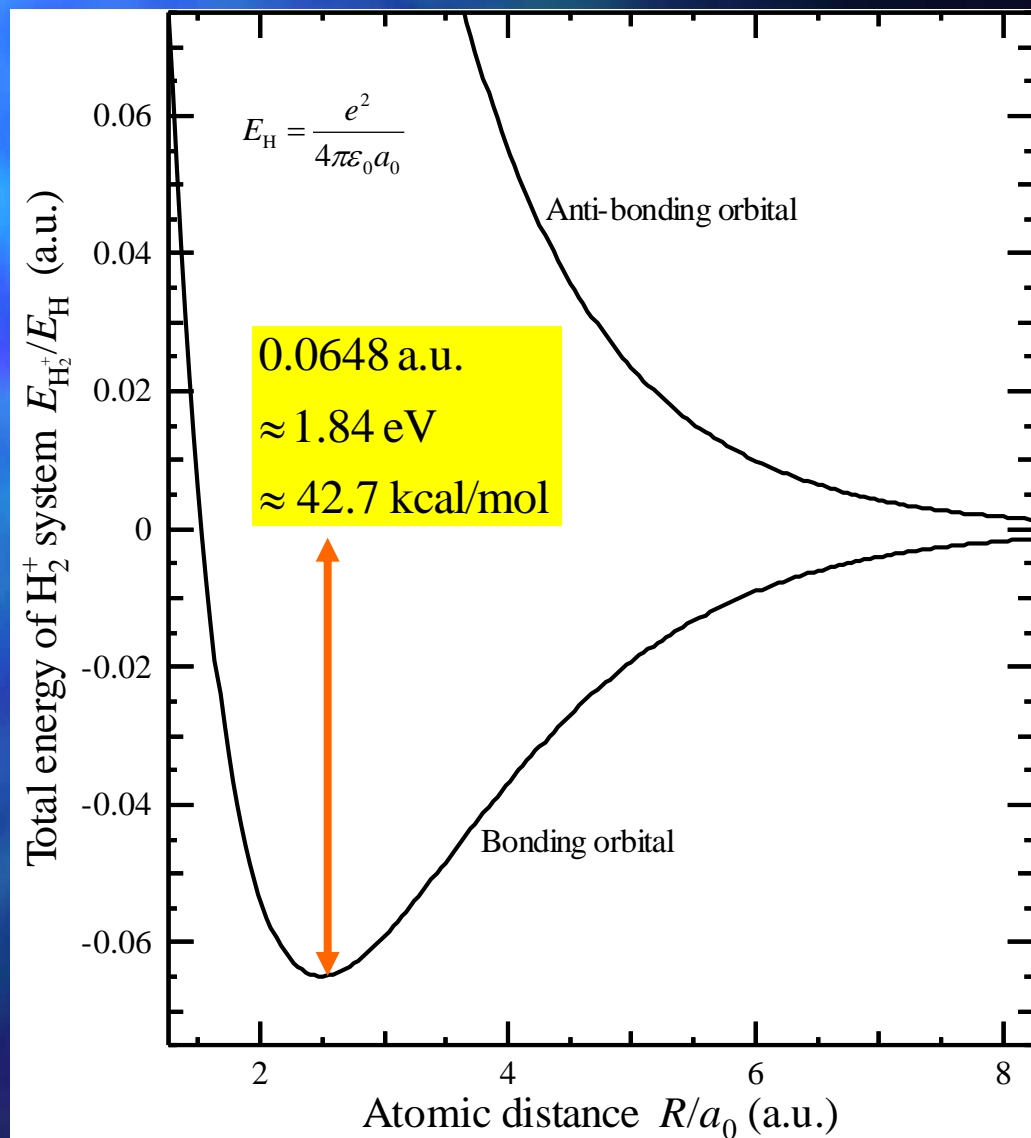
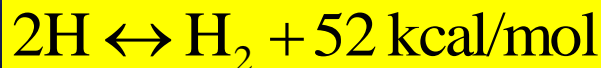

$$\varphi = \pm \frac{\chi_a + \chi_b}{\sqrt{2 + 2S}} : \text{Bonding state}$$

$$\varphi = \pm \frac{\chi_a - \chi_b}{\sqrt{2 - 2S}} : \text{Anti-bonding state}$$

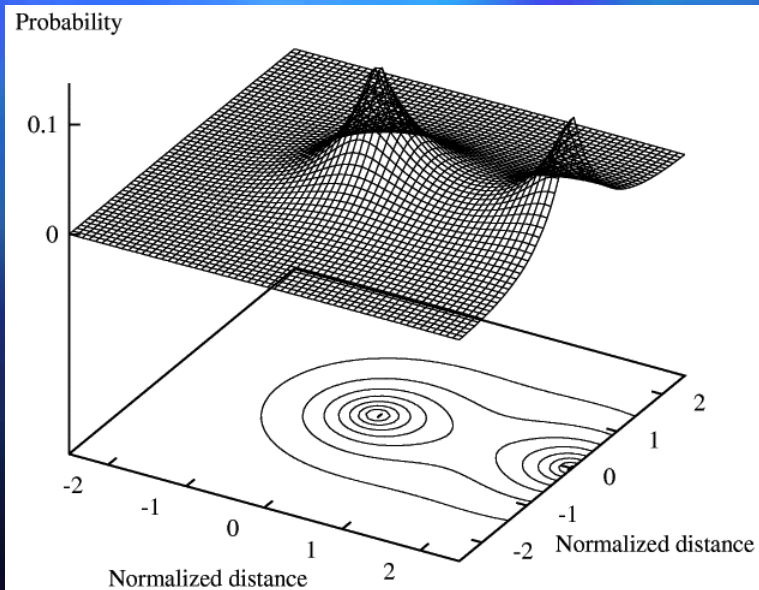

(a) Density of bonding orbital electron

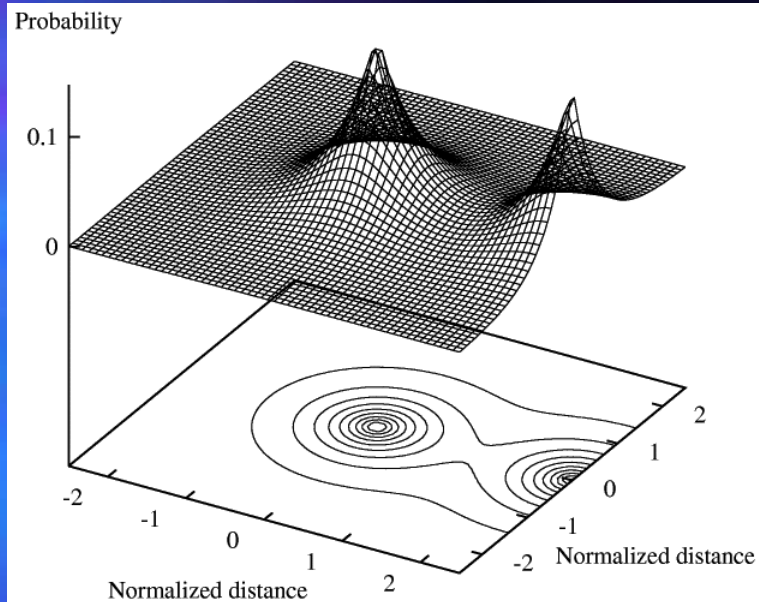

(c) Superimposition of atomic electron density

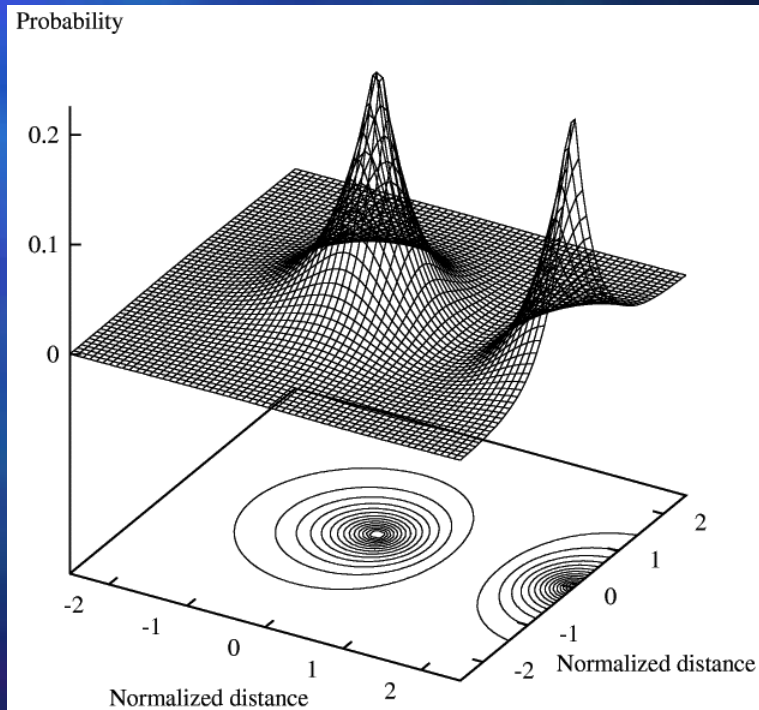

(b) Density of anti-bonding orbital electron

7. Two ionic core with one electron

$$\mathbf{H}\varphi = E\varphi$$

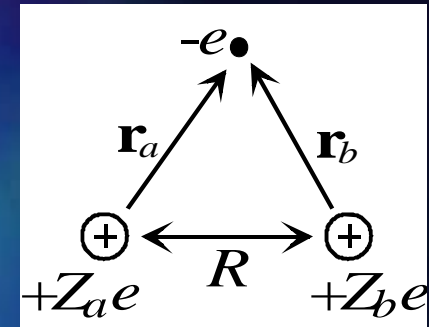

LCAO approximation

$$\varphi = C_a \chi_a + C_b \chi_b$$

$$\int \varphi^2 d\tau = 1$$

$$E = \frac{\int \varphi \mathbf{H} \varphi d\tau}{\int \varphi \varphi d\tau} \rightarrow \min$$

$$\frac{\partial E}{\partial C_a} = \frac{\partial E}{\partial C_b} = 0$$



$$E = \frac{H_{aa} + H_{bb} - 2S_{ab}H_{ab}}{2(1 - S_{ab}^2)} \pm \frac{(H_{aa} - H_{bb})}{2(1 - S_{ab}^2)} \sqrt{1 + 4 \frac{(H_{ab} - S_{ab}H_{aa})(H_{ab} - S_{ab}H_{bb})}{(H_{aa} - H_{bb})^2}}$$

$$H_{aa} = \int \chi_a \mathbf{H} \chi_a d\tau$$

$$H_{bb} = \int \chi_b \mathbf{H} \chi_b d\tau$$

$$H_{ab} = \int \chi_a \mathbf{H} \chi_b d\tau$$

$$S_{ab} = \int \chi_a \chi_b d\tau$$

Large binding energy is due to ...

- large difference between energy levels
- or
- large overlap of wave functions

$$\mathbf{H}\phi = E\phi \quad \mathbf{H} = -\frac{\hbar^2}{2m}\nabla^2 - \frac{1}{4\pi\epsilon_0}\left(\frac{Z_a e^2}{r_a} + \frac{Z_b e^2}{r_b} + \frac{Z_a Z_b e^2}{R}\right)$$

$$E = \frac{H_{aa} + H_{bb} - 2S_{ab}H_{ab}}{2(1 - S_{ab}^2)} \pm \frac{(H_{aa} + H_{bb})}{2(1 - S_{ab}^2)} \sqrt{1 + 4 \frac{(H_{ab} - S_{ab}H_{aa})(H_{ab} - S_{ab}H_{bb})}{(H_{aa} - H_{bb})^2}}$$

$$= E_{ab} \pm \Delta E$$

$$H_{aa} = \int \chi_a H \chi_a d\tau$$

$$H_{bb} = \int \chi_b H \chi_b d\tau$$

$$H_{ab} = \int \chi_a H \chi_b d\tau$$

$$S_{ab} = \int \chi_a \chi_b d\tau$$

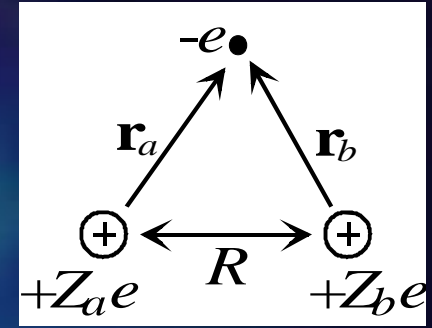

When $H_{aa} \approx H_{bb}$ $S_{ab} \ll 1$

$$E = E_{ab} \pm \Delta E = \frac{H_{aa} + H_{bb}}{2} \pm H_{ab}$$

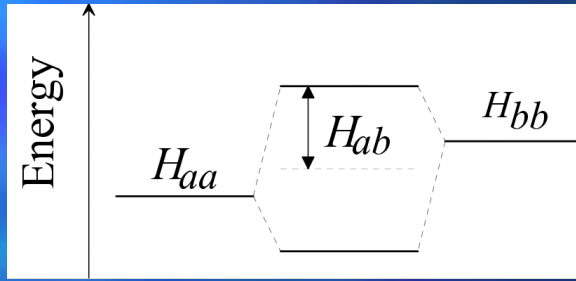

: covalent bond

When $H_{ab} \ll |H_{aa} - H_{bb}|$ $S_{ab} \ll 1$

$$E = E_{ab} \pm \Delta E = \begin{cases} H_{aa} - \frac{H_{ab}^2}{|H_{aa} - H_{bb}|} \\ H_{bb} + \frac{H_{ab}^2}{|H_{aa} - H_{bb}|} \end{cases}$$

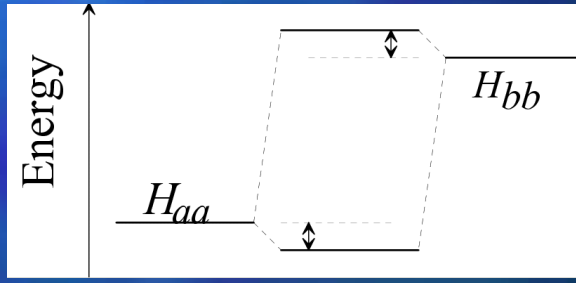

: ionic bond

Large binding energy is due to ...

- large difference between energy levels
- or
- large overlap of wave functions

Ionic bond, Covalent bond, and Metallic bond

consideration with "Two ionic core with one electron model"

Models for each limitation

How understood with Q.M. ?



- **Difference between energy levels.**
Large difference seems charge transfer.
- **Distribution of frontier electrons**
Spherical or localized to directions

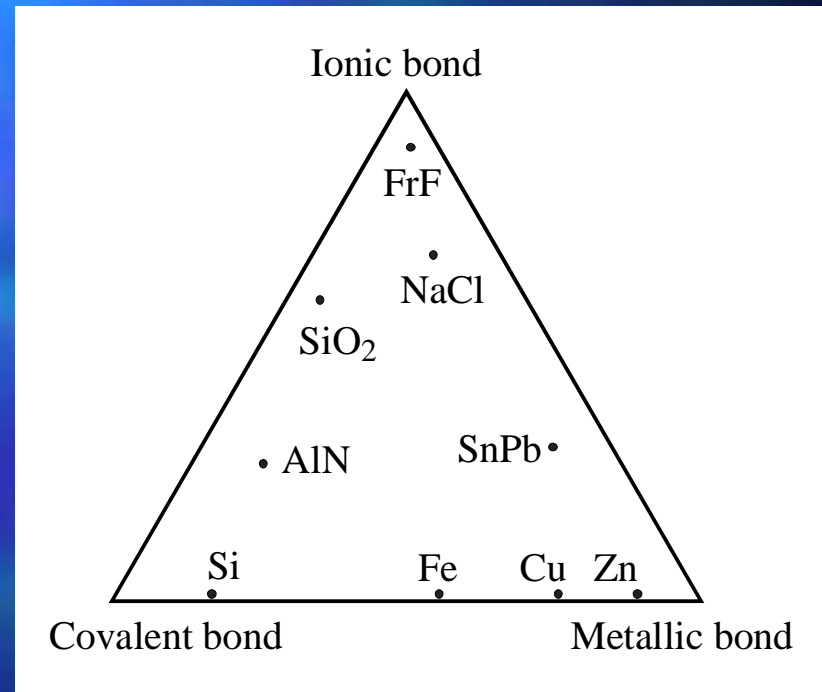

There is neither

- purely-ionic-bond material,
- purely-covalent-bond material,
- nor
- purely-metallic-bond material.

	s		d										p					
	1	2	1	2	3	4	5	6	7	8	9	10	1	2	3	4	5	6
	IA	IIA	IIIA	IVA	VA	VIA	VIIA	VIII			IB	IIIB	IIIB	IVB	VB	VIB	VIIB	0
1	H																	He
2	Li	Be											B	C	N	O	F	Ne
3	Na	Mg											Al	Si	P	S	Cl	Ar
4	K	Ca	Sc	Ti	V	Cr	Mn	Fe	Co	Ni	Cu	Zn	Ga	Ge	As	Se	Br	Kr
5	Rb	Sr	Y	Zr	Nb	Mo	Tc	Ru	Rh	Pd	Ag	Cd	In	Sn	Sb	Te	I	Xe
6	Cs	Ba	*	Hf	Ta	W	Re	Os	Ir	Pt	Au	Hg	Tl	Pb	Bi	Po	At	Rn
7	Fr	Ra	**															

	f															
	1	2	3	4	5	6	7	8	9	10	11	12	13	14		
6	*	La	Ce	Pr	Nd	Pm	Sm	Eu	Gd	Tb	Dy	Ho	Er	Tm	Yb	Lu
7	**	Ac	Th	Pa	U	Np	Pu	Am	Cm	Bk	Cf	Es	Fm	Md	No	Lr

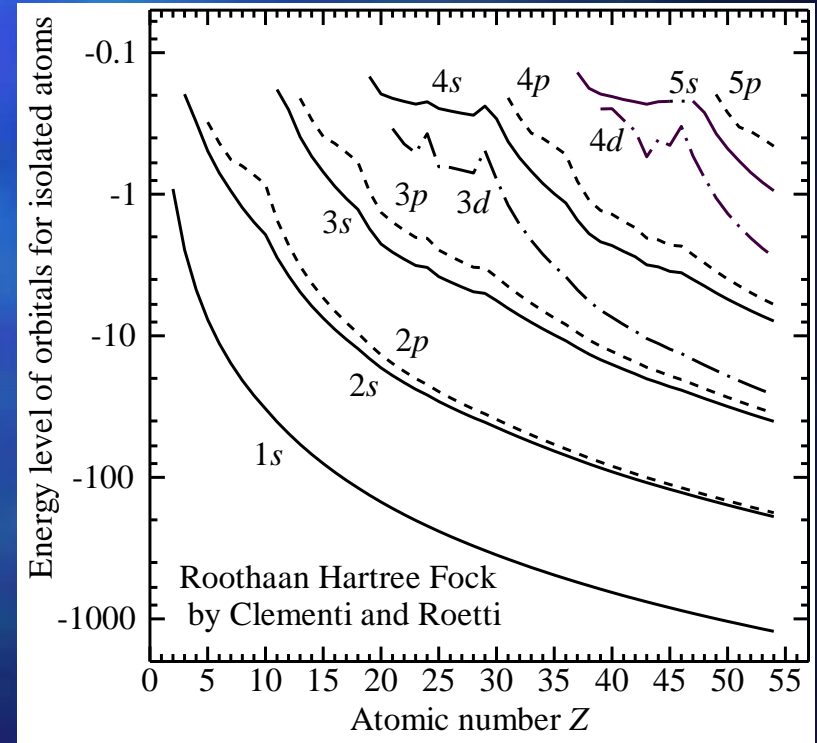
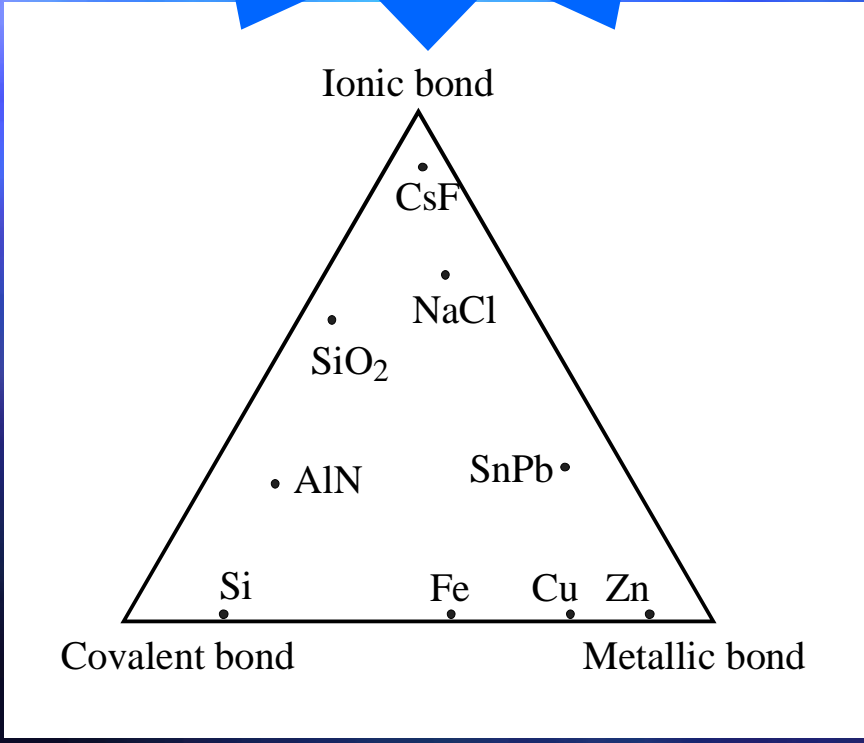

- Difference between energy levels
- Distribution of frontier electrons

Large difference seems charge transfer.

Spherical or localized to directions

Cohesion energy and Periodic table

Shell	K	L	M	N
Principal Q.N.	1	2	3	4
Azimuthal Q.N.	0	0 1	0 1 2	0 1 2
Orbitals	1s	2s 2p	3s 3p 3d	4s 4p 4d
L. Z				
1	1 2	H He	1 2	
2	3 4 5 6 7 8 9 10	Li Be B C N O F Ne	2 2 2 2 2 2 2 2	1 2 1 2 3 4 5 6
3	11 12 13 14 15 16 17 18	Na Mg Al Si P S Cl Ar	2 2 2 2 2 2 2 2	6 6 6 6 6 6 6 6
4	19 20 21 22 23 24 25 26 27 28 29 30 31 32 33 34 35 36	K Ca Sc Ti V Cr Mn Fe Co Ni Cu Zn Ga Ge As Se Br Kr	2 2 2 2 2 2 2 2 2 2 2 2 2 2 2 2 2	6 6 6 6 6 6 6 6 6 6 6 6 6 6 6 6 6
5	37	Rb	2	6

	s		d										p							
	1	2	1	2	3	4	5	6	7	8	9	10	1	2	3	4	5	6		
	IA	IIA	IIIA	IVA	VA	VIA	VIIA	VIII				IB	IIB	IIIB	IVB	VB	VIB	BIIB	0	
1	H																		He	
2	Li	Be													B	C	N	O	F	Ne
3	Na	Mg											Al	Si	P	S	Cl	Ar		
4	K	Ca	Sc	Ti	V	Cr	Mn	Fe	Co	Ni	Cu	Zn	Ga	Ge	As	Se	Br	Kr		
5	Rb	Sr	Y	Zr	Nb	Mo	Tc	Ru	Rh	Pd	Ag	Cd	In	Sn	Sb	Te	I	Xe		
6	Cs	Ba	*	Hf	Ta	W	Re	Os	Ir	Pt	Au	Hg	Tl	Pb	Bi	Po	At	Rn		
7	Fr	Ra	**																	
6	*																			
7	**																			
			f																	
			1	2	3	4	5	6	7	8	9	10	11	12	13	14				
			La	Ce	Pr	Nd	Pm	Sm	Eu	Gd	Tb	Dy	Ho	Er	Tm	Yb	Lu			
			Ac	Th	Pa	U	Np	Pu	Am	Cm	Bk	Cf	Es	Fm	Md	No	Lr			

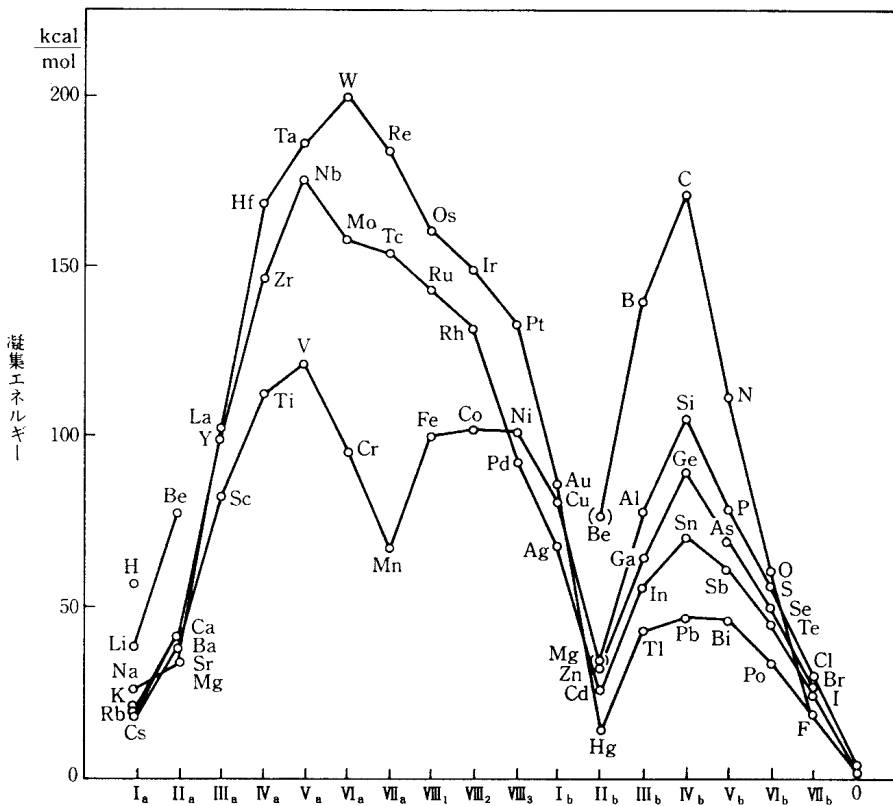

■ Difference between energy levels

■ Distribution of frontier electrons

Cohesion energy and Periodic table

Large difference

Spherical or

Shell	K	L	M	N	O
Principal Q.N.	1	2	3	4	5
Azimuthal Q.N.	0	0 1	0 1 2	0 1 2 3	0 1 2
Orbitals	1s	2s 2p	3s 3p 3d	4s 4p 4d 4f	5s 5p 5d
L. Z					
1	1 2	H He	1 2		
2	3 4 5 6 7 8 9 10	Li Be B C N O F Ne	2 2 2 1 2 2 2 2 3 2 2 4 2 2 5 2 2 6		
3	11 12 13 14 15 16 17 18	Na Mg Al Si P S Cl Ar	2 2 6 2 6 2 6 2 6 2 6 2 6 2 6	1 2 2 1 2 2 2 3 2 4 2 5 2 6	
4	19 20 21 22 23 24 25 26 27 28 29 30 31 32 33 34 35 36	K Ca Sc Ti V Cr Mn Fe Co Ni Cu Zn Ga Ge As Se Br Kr	2 2 6 2 6 2 6 2 6 2 6 2 6 2 6 2 6 2 6 2 6 2 6 2 6 2 6 2 6 2 6 2 6	2 6 2 6 2 6 2 6 2 6 2 6 2 6 2 6 2 6 2 6 2 6 2 6 2 6 2 6 2 6 2 6 2 6	1 2 1 2 2 2 3 2 5 1 5 2 6 2 7 2 8 2 10 1 10 2 10 2 10 3 10 4 10 5 10 6
5	37 ...	Rb ...	2 2 6 2 6 2 6 2 6 2 6 2 6 2 6 2 6 2 6 2 6 2 6 2 6 2 6 2 6 2 6 2 6	2 6 2 6 2 6 2 6 2 6 2 6 2 6 2 6 2 6 2 6 2 6 2 6 2 6 2 6 2 6 2 6 2 6	2 6 2 6 2 6 2 6 2 6 2 6 2 6 2 6 2 6 2 6 2 6 2 6 2 6 2 6 2 6 2 6 2 6

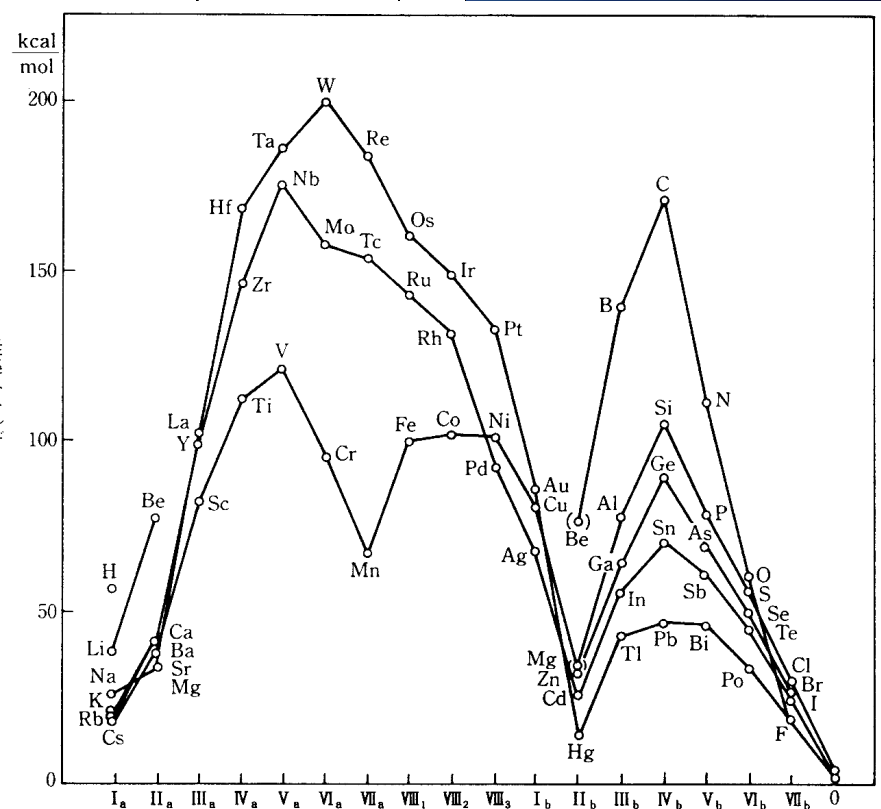
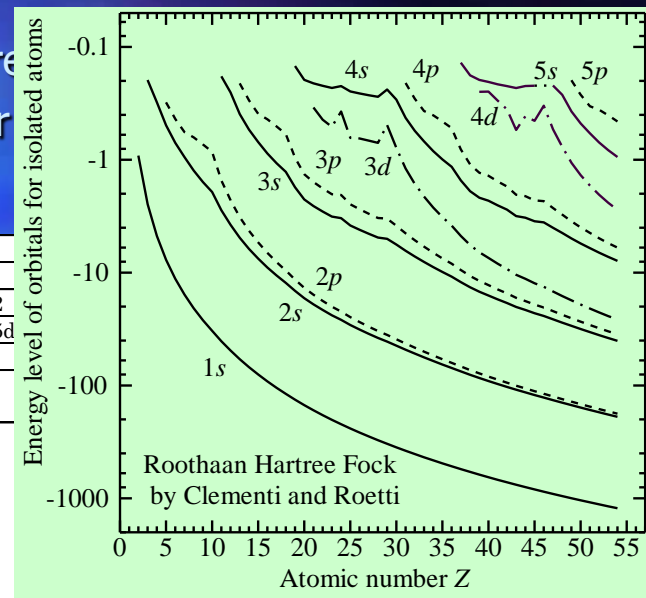

You have obtain a systematic feature of elements ?

Calculation by yourself is essential. Please try it.

Material which shows ...

- the highest melting point (or cohesive energy),
- lager electro-negativity (or smaller ionization energy),
- close-pack structure (fcc,hcp,bcc,sc,dia.,,,,),
- chemical activity (or non-activity)

	<i>s</i>		<i>d</i>										<i>p</i>							
	1	2	1	2	3	4	5	6	7	8	9	10	1	2	3	4	5	6		
	IA	IIA	IIIA	IVA	VA	VIA	VIIA	VIII				IB	IIB	IIIB	IVB	VB	VIB	VIIB	0	
1	H																			He
2	Li	Be											B	C	N	O	F		Ne	
3	Na	Mg											Al	Si	P	S	Cl		Ar	
4	K	Ca	Sc	Ti	V	Cr	Mn	Fe	Co	Ni	Cu	Zn	Ga	Ge	As	Se	Br	Kr		
5	Rb	Sr	Y	Zr	Nb	Mo	Tc	Ru	Rh	Pd	Ag	Cd	In	Sn	Sb	Te	I	Xe		
6	Cs	Ba	*	Hf	Ta	W	Re	Os	Ir	Pt	Au	Hg	Tl	Pb	Bi	Po	At	Rn		
7	Fr	Ra	**																	
			<i>f</i>																	
			1	2	3	4	5	6	7	8	9	10	11	12	13	14				
6	*		La	Ce	Pr	Nd	Pm	Sm	Eu	Gd	Tb	Dy	Ho	Er	Tm	Yb	Lu			
7	**		Ac	Th	Pa	U	Np	Pu	Am	Cm	Bk	Cf	Es	Fm	Md	No	Lr			

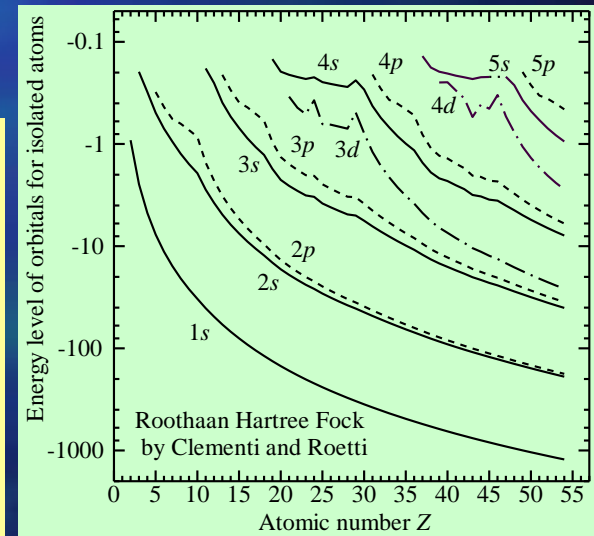

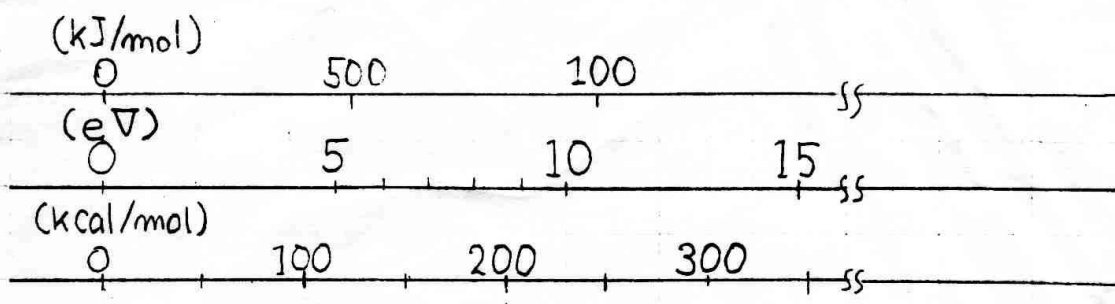

(NaCl) (LiF)
イオン結合

Ge Si
共有結合

Ni Fe
金属結合

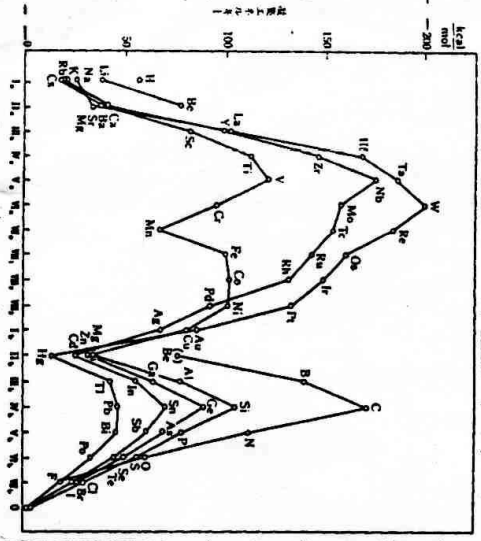

H₂O
水素結合

reference
↓
(物理学辞典) 接着百科
"
"

$$\begin{aligned}
 1 \text{ kJ/mol} &= 1 \times 10^3 \text{ J/mol} \\
 &= 1 \times 10^3 / 6.02209 \times 10^{23} \text{ J/個} \\
 &= 1 \times 10^3 / 6.02209 \times 10^{23} \\
 &\quad \times 6.23 \times 10^{18} \text{ eV/個} \\
 &= 1.035 \times 10^{-2} \text{ eV/個}
 \end{aligned}$$

金属 1984年11月
P.572 61

$$\begin{aligned}
 1 \text{ kcal/mol} &= 4.184 \text{ kJ/mol} \\
 &= 4.330 \times 10^{-2} \text{ eV/個}
 \end{aligned}$$

物理学小冊

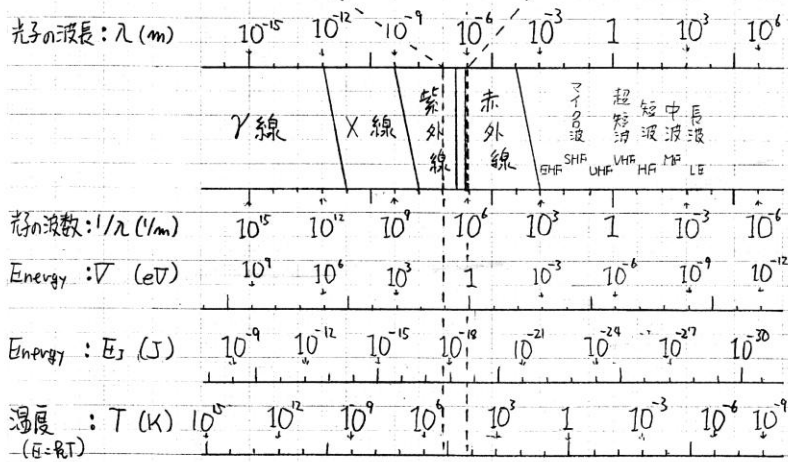
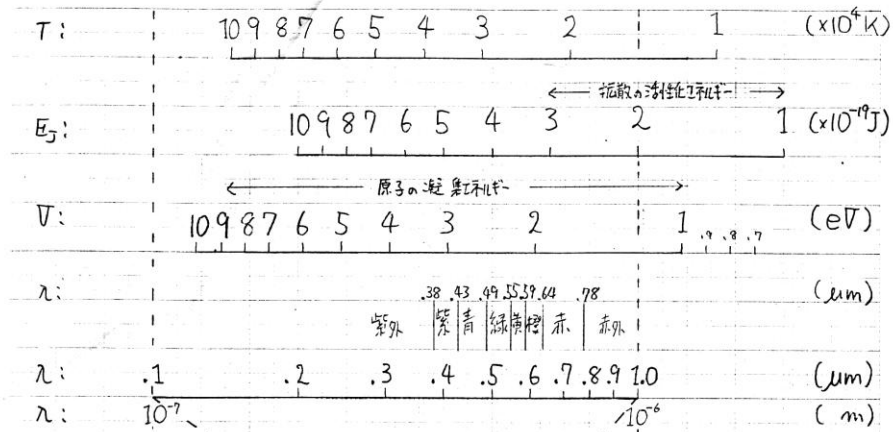

$1/\lambda$ ($1/\text{m}$)	E_J (J)	V (eV)	T (K)
1	1.99×10^{-25}	1.24×10^{-6}	1.44×10^{-2}
5.03×10^{24}	1	6.23×10^{18}	7.24×10^{22}
8.07×10^5	1.60×10^{-19}	1	1.16×10^4
6.94×10^1	1.38×10^{-23}	8.61×10^{-5}	1

$R_L = R_C \cdot L = F = \rho \cdot \nu = kT$

8. Neutral He atom (1)

as an example for isolated neutral atoms

	s		d								p							
	1	2	1	2	3	4	5	6	7	8	9	10	1	2	3	4	5	6
	IA	IIA	IIIA	IVA	VA	VIA	VIIA	VIII			IB	IIB	IIIB	IVB	VB	VIB	BIB	0
1	H																	He
2	Li	Be											B	C	N	O	F	Ne
3	Na	Mg											Al	Si	P	S	Cl	Ar
4	K	Ca	Sc	Ti	V	Cr	Mn	Fe	Co	Ni	Cu	Zn	Ga	Ge	As	Se	Br	Kr
5	Rb	Sr	Y	Zr	Nb	Mo	Tc	Ru	Rh	Pd	Ag	Cd	In	Sn	Sb	Te	I	Xe
6	Cs	Ba	*	Hf	Ta	W	Re	Os	Ir	Pt	Au	Hg	Tl	Pb	Bi	Po	At	Rn
7	Fr	Ra	**															
6		*																
7		**																

- Spin-orbital**

Two electrons in 1s orbital.

$$\phi_1 = \phi_{1s}\alpha \quad \phi_2 = \phi_{1s}\beta$$

- Integration with spin coordinate**

$$\chi = \psi^* \int \psi d\tau = \psi^* \int \psi dV ds = \psi^* \int \psi dx dy dz ds$$

$$d\tau = dV ds = dx dy dz ds$$

- Ortho-normality**

$$\int \phi_k(\mathbf{r}_i) \phi_l(\mathbf{r}_i) d\tau_i = \delta_{k,l}$$



– orbital term

$$\int \phi_m(\mathbf{r}_i) \phi_n(\mathbf{r}_i) dV_i = \delta_{m,n}$$

– spin term

$$\int \alpha(\mathbf{r}_i) \alpha(\mathbf{r}_i) ds_i = 1$$

$$\int \beta(\mathbf{r}_i) \beta(\mathbf{r}_i) ds_i = 1$$

$$\int \alpha(\mathbf{r}_i) \beta(\mathbf{r}_i) ds_i = 0$$

$$\psi(\mathbf{r}_1, \dots, \mathbf{r}_N) = \frac{1}{\sqrt{N!}} \begin{vmatrix} \phi_1(\mathbf{r}_1) & \dots & \phi_1(\mathbf{r}_N) \\ \vdots & & \vdots \\ \phi_N(\mathbf{r}_1) & \dots & \phi_N(\mathbf{r}_N) \end{vmatrix}$$

8. Neutral He atom (2)

as an example for isolated neutral atoms

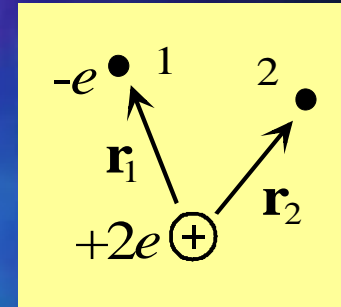

- Schrödinger equation

$$\mathbf{H}\psi = \epsilon\psi$$

$$\psi(\mathbf{r}_1, \mathbf{r}_2) = \frac{1}{\sqrt{2!}} \begin{vmatrix} \phi_1(\mathbf{r}_1) & \phi_1(\mathbf{r}_2) \\ \phi_2(\mathbf{r}_1) & \phi_2(\mathbf{r}_2) \end{vmatrix} = \frac{1}{\sqrt{2!}} \begin{vmatrix} \phi_1(1) & \phi_1(2) \\ \phi_2(1) & \phi_2(2) \end{vmatrix}$$

$$\phi_1(i) = \varphi_{1s}(i)\alpha(i)$$

$$\phi_2(i) = \varphi_{1s}(i)\beta(i)$$

$$\begin{aligned} \mathbf{H} &= -\frac{\hbar^2}{2m} (\nabla_1^2 + \nabla_2^2) - \frac{1}{4\pi\epsilon_0} \left(\frac{2e^2}{|\mathbf{r}_1|} + \frac{2e^2}{|\mathbf{r}_2|} \right) + \frac{1}{4\pi\epsilon_0} \frac{e^2}{|\mathbf{r}_1 - \mathbf{r}_2|} \\ &= \left(-\frac{\hbar^2}{2m} \nabla_1^2 - \frac{1}{4\pi\epsilon_0} \frac{2e^2}{|\mathbf{r}_1|} \right) + \left(-\frac{\hbar^2}{2m} \nabla_2^2 - \frac{1}{4\pi\epsilon_0} \frac{2e^2}{|\mathbf{r}_2|} \right) + \left(\frac{1}{4\pi\epsilon_0} \frac{e^2}{|\mathbf{r}_1 - \mathbf{r}_2|} \right) \\ &= \mathbf{H}_1 + \mathbf{H}_2 + \mathbf{H}_e \end{aligned}$$

- Remember "one ion - one electron model"

$$-e \bullet Z_a = 2$$

$$+Z_a e \oplus \chi_{1s}, \chi_{2s}, \chi_{2p}, \chi_{3s}, \dots$$

$$\varphi_{1s} = C_{1s}\chi_{1s} + C_{2s}\chi_{2s} + C_{3s}\chi_{3s} + \dots$$

$$\varphi_{1s} = C_{G1}\chi_{G1} + C_{G2}\chi_{G2} + C_{G3}\chi_{G3} + \dots$$

8. Neutral He atom (3)

as an example for isolated neutral atoms

$$\psi(\mathbf{r}_1, \mathbf{r}_2) = \frac{1}{\sqrt{2!}} \begin{vmatrix} \phi_1(\mathbf{r}_1) & \phi_1(\mathbf{r}_2) \\ \phi_2(\mathbf{r}_1) & \phi_2(\mathbf{r}_2) \end{vmatrix} = \frac{1}{\sqrt{2!}} \begin{vmatrix} \phi_1(1) & \phi_1(2) \\ \phi_2(1) & \phi_2(2) \end{vmatrix}$$

$$\phi_1 = \varphi_{1s}\alpha$$

$$\phi_2 = \varphi_{1s}\beta$$

Total energy

$$E = \int \psi^* \mathbf{H} \psi d\tau = \int \psi^* \mathbf{H}_1 \psi d\tau + \int \psi^* \mathbf{H}_2 \psi d\tau + \int \psi^* \mathbf{H}_e \psi d\tau$$

$$\begin{aligned} \int \psi^* \mathbf{H}_1 \psi d\tau &= \frac{1}{2} \int (\phi_1(1)\phi_2(2) - \phi_1(2)\phi_2(1))^* \mathbf{H}_1 (\phi_1(1)\phi_2(2) - \phi_1(2)\phi_2(1)) d\tau \\ &= \frac{1}{2} \int (\varphi_{1s}(1)\alpha(1)\varphi_{1s}(2)\beta(2) - \varphi_{1s}(2)\alpha(2)\varphi_{1s}(1)\beta(1))^* \mathbf{H}_1 (\varphi_{1s}(1)\alpha(1)\varphi_{1s}(2)\beta(2) - \varphi_{1s}(2)\alpha(2)\varphi_{1s}(1)\beta(1)) d\tau \\ &= \frac{1}{2} \int (\varphi_{1s}(1)\alpha(1)\varphi_{1s}(2)\beta(2))^* \mathbf{H}_1 (\varphi_{1s}(1)\alpha(1)\varphi_{1s}(2)\beta(2)) d\tau \\ &\quad + \frac{1}{2} \int (\varphi_{1s}(2)\alpha(2)\varphi_{1s}(1)\beta(1))^* \mathbf{H}_1 (\varphi_{1s}(2)\alpha(2)\varphi_{1s}(1)\beta(1)) d\tau \\ &\quad - \frac{1}{2} \int (\varphi_{1s}(1)\alpha(1)\varphi_{1s}(2)\beta(2))^* \mathbf{H}_1 (\varphi_{1s}(2)\alpha(2)\varphi_{1s}(1)\beta(1)) d\tau \\ &\quad - \frac{1}{2} \int (\varphi_{1s}(2)\alpha(2)\varphi_{1s}(1)\beta(1))^* \mathbf{H}_1 (\varphi_{1s}(1)\alpha(1)\varphi_{1s}(2)\beta(2)) d\tau \end{aligned}$$

$$\begin{aligned} &\frac{1}{2} \int (\varphi_{1s}(1)\alpha(1)\varphi_{1s}(2)\beta(2))^* \mathbf{H}_1 (\varphi_{1s}(1)\alpha(1)\varphi_{1s}(2)\beta(2)) d\tau \\ &= \frac{1}{2} \int \varphi_{1s}(2)\beta(2)\varphi_{1s}(2)\beta(2) d\tau_2 \int (\varphi_{1s}(1)\alpha(1))^* \mathbf{H}_1 (\varphi_{1s}(1)\alpha(1)) d\tau_1 \\ &= \frac{1}{2} \int \varphi_{1s}(2)\varphi_{1s}(2) dV_2 \int \beta(2)\beta(2) ds_2 \int \alpha(1)\alpha(1) ds_1 \int \varphi_{1s}(1)^* \mathbf{H}_1 \varphi_{1s}(1) dV_1 \\ &= \frac{1}{2} \int \varphi_{1s}(1)^* \mathbf{H}_1 \varphi_{1s}(1) dV_1 \end{aligned}$$

$$\begin{aligned} &\frac{1}{2} \int (\varphi_{1s}(2)\alpha(2)\varphi_{1s}(1)\beta(1))^* \mathbf{H}_1 (\varphi_{1s}(2)\alpha(2)\varphi_{1s}(1)\beta(1)) d\tau \\ &= \frac{1}{2} \int \varphi_{1s}(2)\beta(2)\varphi_{1s}(2)\beta(2) d\tau_2 \int (\varphi_{1s}(1)\alpha(1))^* \mathbf{H}_1 (\varphi_{1s}(1)\alpha(1)) d\tau_1 \\ &= \frac{1}{2} \int \varphi_{1s}(2)\varphi_{1s}(2) dV_2 \int \beta(2)\beta(2) ds_2 \int \alpha(1)\alpha(1) ds_1 \int \varphi_{1s}(1)^* \mathbf{H}_1 \varphi_{1s}(1) dV_1 \\ &= \frac{1}{2} \int \varphi_{1s}(1)^* \mathbf{H}_1 \varphi_{1s}(1) dV_1 \end{aligned}$$

$$E = \int \psi^* \mathbf{H} \psi d\tau = \int \psi^* \mathbf{H}_1 \psi d\tau + \int \psi^* \mathbf{H}_2 \psi d\tau + \int \psi^* \mathbf{H}_e \psi d\tau$$

$$\psi(\mathbf{r}_1, \mathbf{r}_2) = \frac{1}{\sqrt{2!}} \begin{vmatrix} \phi_1(\mathbf{r}_1) & \phi_1(\mathbf{r}_2) \\ \phi_2(\mathbf{r}_1) & \phi_2(\mathbf{r}_2) \end{vmatrix} = \frac{1}{\sqrt{2!}} \begin{vmatrix} \phi_1(1) & \phi_1(2) \\ \phi_2(1) & \phi_2(2) \end{vmatrix}$$

$$\begin{aligned} \int \psi^* \mathbf{H}_1 \psi d\tau &= \frac{1}{2} \int (\phi_1(1)\phi_2(2) - \phi_1(2)\phi_2(1))^* \mathbf{H}_1 (\phi_1(1)\phi_2(2) - \phi_1(2)\phi_2(1)) d\tau \\ &= \frac{1}{2} \int (\varphi_{1s}(1)\alpha(1)\varphi_{1s}(2)\beta(2) - \varphi_{1s}(2)\alpha(2)\varphi_{1s}(1)\beta(1))^* \mathbf{H}_1 (\varphi_{1s}(1)\alpha(1)\varphi_{1s}(2)\beta(2) - \varphi_{1s}(2)\alpha(2)\varphi_{1s}(1)\beta(1)) d\tau \\ &= \frac{1}{2} \int (\varphi_{1s}(1)\alpha(1)\varphi_{1s}(2)\beta(2))^* \mathbf{H}_1 (\varphi_{1s}(1)\alpha(1)\varphi_{1s}(2)\beta(2)) d\tau \\ &\quad + \frac{1}{2} \int (\varphi_{1s}(2)\alpha(2)\varphi_{1s}(1)\beta(1))^* \mathbf{H}_1 (\varphi_{1s}(2)\alpha(2)\varphi_{1s}(1)\beta(1)) d\tau \\ &\quad - \frac{1}{2} \int (\varphi_{1s}(1)\alpha(1)\varphi_{1s}(2)\beta(2))^* \mathbf{H}_1 (\varphi_{1s}(2)\alpha(2)\varphi_{1s}(1)\beta(1)) d\tau \\ &\quad - \frac{1}{2} \int (\varphi_{1s}(2)\alpha(2)\varphi_{1s}(1)\beta(1))^* \mathbf{H}_1 (\varphi_{1s}(1)\alpha(1)\varphi_{1s}(2)\beta(2)) d\tau \end{aligned}$$

$$= \frac{1}{2} \int \varphi_{1s}(1)^* \mathbf{H}_1 \varphi_{1s}(1) dV_1$$

$$\frac{1}{2} \int (\varphi_{1s}(1)\alpha(1)\varphi_{1s}(2)\beta(2))^* \mathbf{H}_1 (\varphi_{1s}(2)\alpha(2)\varphi_{1s}(1)\beta(1)) d\tau$$

$$= \frac{1}{2} \int \varphi_{1s}(2)\beta(2)\varphi_{1s}(2)\alpha(2) d\tau_2 \int (\varphi_{1s}(1)\alpha(1))^* \mathbf{H}_1 (\varphi_{1s}(1)\beta(1)) d\tau_1$$

$$= \frac{1}{2} \int \varphi_{1s}(2)\varphi_{1s}(2) dV_2 \int \beta(2)\alpha(2) ds_2 \int \alpha(1)\beta(1) ds_1 \int \varphi_{1s}(1)^* \mathbf{H}_1 \varphi_{1s}(1) dV_1 = 0$$

$$\frac{1}{2} \int (\varphi_{1s}(2)\alpha(2)\varphi_{1s}(1)\beta(1))^* \mathbf{H}_1 (\varphi_{1s}(1)\alpha(1)\varphi_{1s}(2)\beta(2)) d\tau$$

$$= \frac{1}{2} \int \varphi_{1s}(2)\alpha(2)\varphi_{1s}(2)\beta(2) d\tau_2 \int (\varphi_{1s}(1)\beta(1))^* \mathbf{H}_1 (\varphi_{1s}(1)\alpha(1)) d\tau_1$$

$$= \frac{1}{2} \int \varphi_{1s}(2)\varphi_{1s}(2) dV_2 \int \alpha(2)\beta(2) ds_2 \int \beta(1)\alpha(1) ds_1 \int \varphi_{1s}(1)^* \mathbf{H}_1 \varphi_{1s}(1) dV_1 = 0$$

$$\int \psi^* \mathbf{H}_1 \psi d\tau = \int \varphi_{1s}(1)^* \mathbf{H}_1 \varphi_{1s}(1) d\tau_1$$

$$\int \psi^* \mathbf{H}_2 \psi d\tau = \int \varphi_{1s}(2)^* \mathbf{H}_2 \varphi_{1s}(2) d\tau_2$$

$$E = \int \psi^* \mathbf{H} \psi d\tau = \int \psi^* \mathbf{H}_1 \psi d\tau + \int \psi^* \mathbf{H}_2 \psi d\tau + \int \psi^* \mathbf{H}_e \psi d\tau$$

$$\begin{aligned} \int \psi^* \mathbf{H}_e \psi d\tau &= \frac{1}{2} \int (\phi_1(1)\phi_2(2) - \phi_1(2)\phi_2(1))^* \mathbf{H}_e (\phi_1(1)\phi_2(2) - \phi_1(2)\phi_2(1)) d\tau \\ &= \frac{1}{2} \int (\varphi_{1s}(1)\alpha(1)\varphi_{1s}(2)\beta(2) - \varphi_{1s}(2)\alpha(2)\varphi_{1s}(1)\beta(1))^* \mathbf{H}_e (\varphi_{1s}(1)\alpha(1)\varphi_{1s}(2)\beta(2) - \varphi_{1s}(2)\alpha(2)\varphi_{1s}(1)\beta(1)) d\tau \\ &= \frac{1}{2} \int (\varphi_{1s}(1)\alpha(1)\varphi_{1s}(2)\beta(2))^* \mathbf{H}_e (\varphi_{1s}(1)\alpha(1)\varphi_{1s}(2)\beta(2)) d\tau \rightarrow \frac{1}{2} \iint (\varphi_{1s}(1)\varphi_{1s}(2))^* \mathbf{H}_e (\varphi_{1s}(1)\varphi_{1s}(2)) dV_1 dV_2 \\ &+ \frac{1}{2} \int (\varphi_{1s}(2)\alpha(2)\varphi_{1s}(1)\beta(1))^* \mathbf{H}_e (\varphi_{1s}(2)\alpha(2)\varphi_{1s}(1)\beta(1)) d\tau \rightarrow \frac{1}{2} \iint (\varphi_{1s}(2)\varphi_{1s}(1))^* \mathbf{H}_e (\varphi_{1s}(2)\varphi_{1s}(1)) dV_1 dV_2 \\ &- \frac{1}{2} \int (\varphi_{1s}(1)\alpha(1)\varphi_{1s}(2)\beta(2))^* \mathbf{H}_e (\varphi_{1s}(2)\alpha(2)\varphi_{1s}(1)\beta(1)) d\tau \rightarrow 0 \\ &- \frac{1}{2} \int (\varphi_{1s}(2)\alpha(2)\varphi_{1s}(1)\beta(1))^* \mathbf{H}_e (\varphi_{1s}(1)\alpha(1)\varphi_{1s}(2)\beta(2)) d\tau \rightarrow 0 \\ &= \frac{1}{2} \iint (\varphi_{1s}(1)\varphi_{1s}(2))^* \mathbf{H}_e (\varphi_{1s}(1)\varphi_{1s}(2)) dV_1 dV_2 \\ &+ \frac{1}{2} \iint (\varphi_{1s}(2)\varphi_{1s}(1))^* \mathbf{H}_e (\varphi_{1s}(2)\varphi_{1s}(1)) dV_1 dV_2 \end{aligned}$$

$$\begin{aligned} \int \psi^* \mathbf{H}_e \psi d\tau &= \frac{1}{2} \iint (\varphi_{1s}(1)\varphi_{1s}(2))^* \mathbf{H}_e (\varphi_{1s}(1)\varphi_{1s}(2)) dV_1 dV_2 \\ &+ \frac{1}{2} \iint (\varphi_{1s}(2)\varphi_{1s}(1))^* \mathbf{H}_e (\varphi_{1s}(2)\varphi_{1s}(1)) dV_1 dV_2 \\ &= \iint (\varphi_{1s}(1)\varphi_{1s}(2))^* \mathbf{H}_e (\varphi_{1s}(1)\varphi_{1s}(2)) dV_1 dV_2 \end{aligned}$$

$$\int \psi^* \mathbf{H}_1 \psi d\tau = \int \varphi_{1s}(1)^* \mathbf{H}_1 \varphi_{1s}(1) d\tau_1 \quad \int \psi^* \mathbf{H}_2 \psi d\tau = \int \varphi_{1s}(2)^* \mathbf{H}_2 \varphi_{1s}(2) d\tau_2$$

$$\begin{aligned} \int \psi^* \mathbf{H}_e \psi d\tau &= \frac{1}{2} \iint (\varphi_{1s}(1) \varphi_{1s}(2))^* \mathbf{H}_e (\varphi_{1s}(1) \varphi_{1s}(2)) dV_1 dV_2 \\ &\quad + \frac{1}{2} \iint (\varphi_{1s}(2) \varphi_{1s}(1))^* \mathbf{H}_e (\varphi_{1s}(2) \varphi_{1s}(1)) dV_1 dV_2 \\ &= \iint (\varphi_{1s}(1) \varphi_{1s}(2))^* \mathbf{H}_e (\varphi_{1s}(1) \varphi_{1s}(2)) dV_1 dV_2 \end{aligned}$$

$$\begin{aligned} \mathbf{H} &= -\frac{\hbar^2}{2m} (\nabla_1^2 + \nabla_2^2) - \frac{1}{4\pi\epsilon_0} \left(\frac{2e^2}{|\mathbf{r}_1|} + \frac{2e^2}{|\mathbf{r}_2|} \right) + \frac{1}{4\pi\epsilon_0} \frac{e^2}{|\mathbf{r}_1 - \mathbf{r}_2|} \\ &= \left(-\frac{\hbar^2}{2m} \nabla_1^2 - \frac{1}{4\pi\epsilon_0} \frac{2e^2}{|\mathbf{r}_1|} \right) + \left(-\frac{\hbar^2}{2m} \nabla_2^2 - \frac{1}{4\pi\epsilon_0} \frac{2e^2}{|\mathbf{r}_2|} \right) + \left(\frac{1}{4\pi\epsilon_0} \frac{e^2}{|\mathbf{r}_1 - \mathbf{r}_2|} \right) \\ &= \mathbf{H}_1 + \mathbf{H}_2 + \mathbf{H}_e \end{aligned}$$

$$\begin{aligned} E &= \int \psi^* \mathbf{H} \psi d\tau = \int \psi^* \mathbf{H}_1 \psi d\tau + \int \psi^* \mathbf{H}_2 \psi d\tau + \int \psi^* \mathbf{H}_e \psi d\tau \\ &= 2 \int \varphi_{1s}(1)^* \mathbf{H}_1 \varphi_{1s}(1) dV_1 + \iint (\varphi_{1s}(1) \varphi_{1s}(2))^* \mathbf{H}_e (\varphi_{1s}(1) \varphi_{1s}(2)) dV_1 dV_2 \end{aligned}$$

$$\varphi_{1s}(i) = \sum_{j=1}^L c_{1s,j} \chi_j(i) = c_{1s,1} \chi_1(i) + c_{1s,2} \chi_2(i) + \dots$$

9. Neutral isolated atoms

- Roothaan Hartree Fock approximation

E.Clementi and C.Roetti, Atomic Data and Nuclear Data Tables, 14, 177-478 (1974)

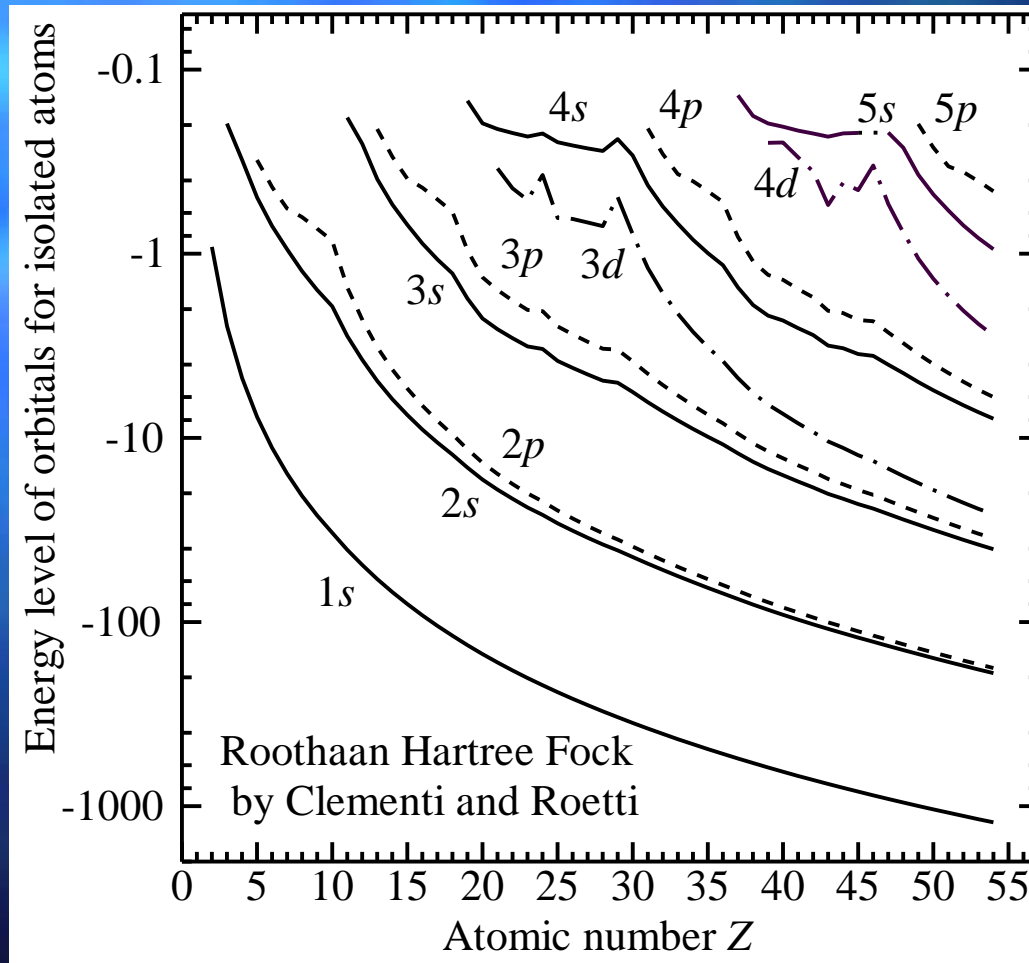

Energy level of neutral atoms

Effect of e⁻e⁻ interaction

$$E_n = -\frac{me^4}{2\hbar^2(4\pi\epsilon_0)^2} \left(\frac{Z_a}{n}\right)^2$$

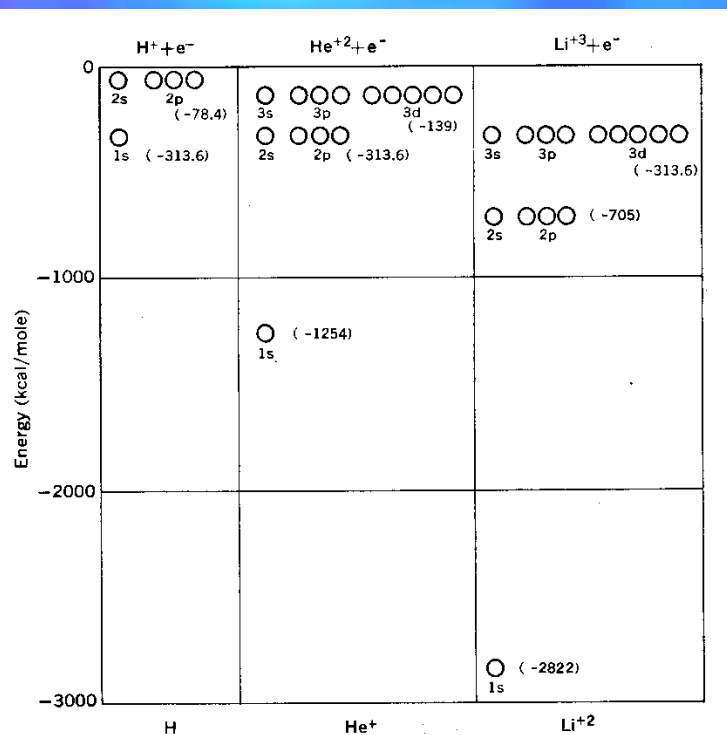

Figure 1-17 Energy level diagrams of one-electron atoms and ions.

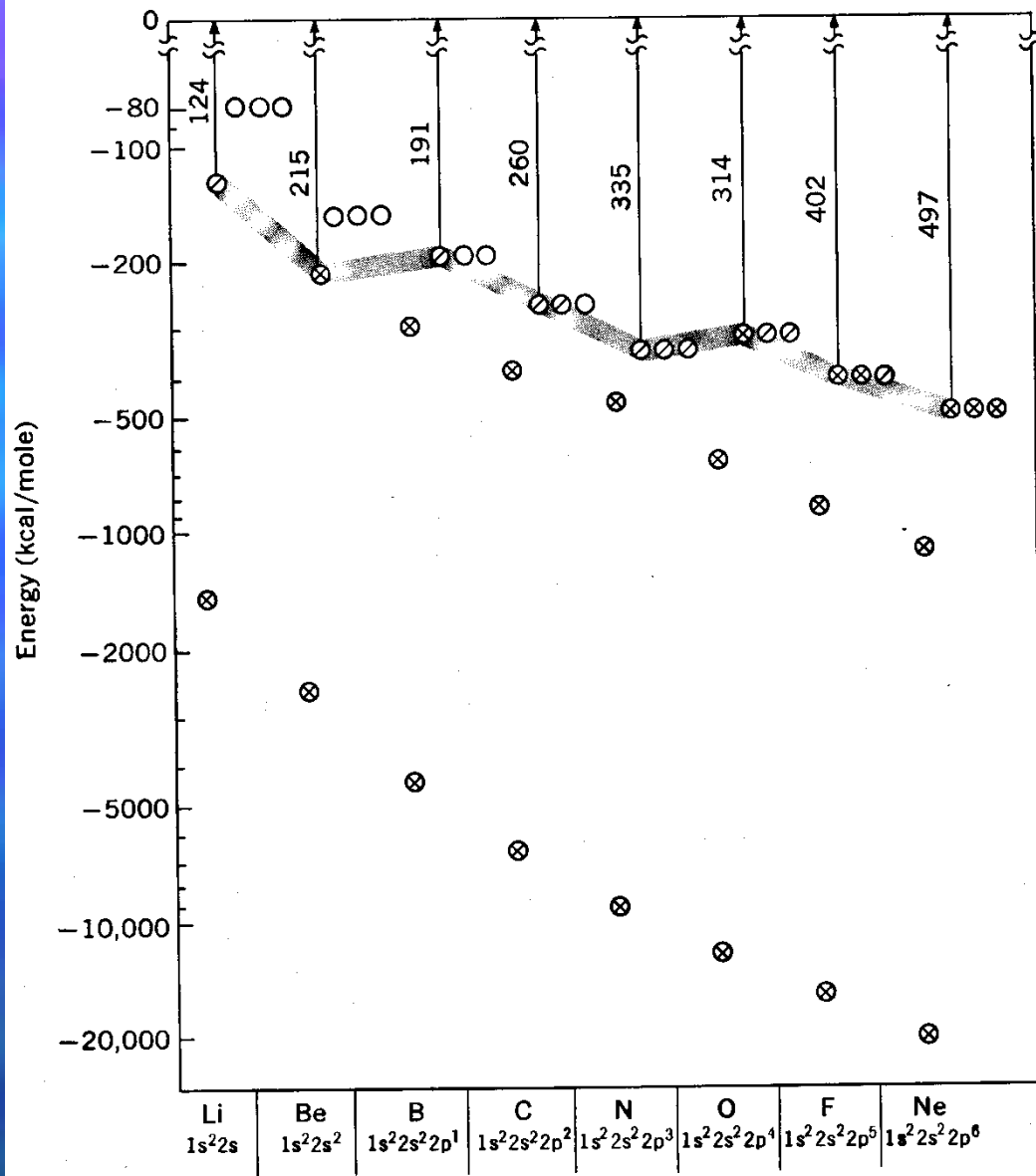

Figure 2-3 Energy levels, orbital occupancy and ionization energies for first-row elements. (Notice scale compression with rising energy.)

One electron systems

Multi-electron systems

10. Diatomic molecules

LCAO

One-electron approximation

Multi-electron effect



We can imagine based on

- **Overlap** of atomic wave functions
 - **Sign** of atomic wave functions
-
- Do you know “ π -bond and σ -bond” ?

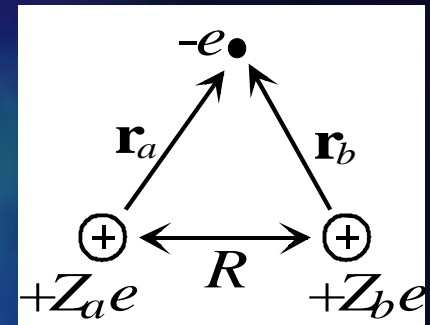

" π -bond and σ -bond"

At first, remember

$$\mathbf{H}\varphi = E\varphi \quad \mathbf{H} = -\frac{\hbar^2}{2m}\nabla^2 - \frac{1}{4\pi\epsilon_0}\left(\frac{Z_a e^2}{r_a} + \frac{Z_b e^2}{r_b} + \frac{Z_a Z_b e^2}{R}\right)$$

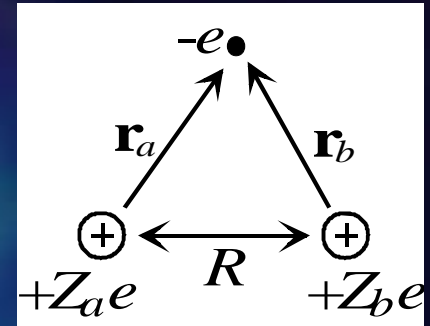

$$E = \frac{H_{aa} + H_{bb} - 2S_{ab}H_{ab}}{2(1 - S_{ab}^2)} \pm \frac{(H_{aa} + H_{bb})}{2(1 - S_{ab}^2)} \sqrt{1 + 4 \frac{(H_{ab} - S_{ab}H_{aa})(H_{ab} - S_{ab}H_{bb})}{(H_{aa} - H_{bb})^2}} = E_{ab} \pm \Delta E$$

When $H_{aa} \approx H_{bb}$ $S_{ab} \ll 1$

$$E = E_{ab} \pm \Delta E = \frac{H_{aa} + H_{bb}}{2} \pm H_{ab}$$

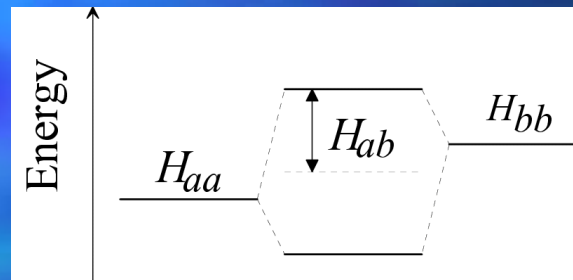

: covalent bond

When $H_{ab} \ll |H_{aa} - H_{bb}|$ $S_{ab} \ll 1$

$$E = E_{ab} \pm \Delta E = \begin{cases} H_{aa} + \frac{H_{ab}^2}{2|H_{aa} - H_{bb}|} \\ H_{bb} - \frac{H_{ab}^2}{2|H_{aa} - H_{bb}|} \end{cases}$$

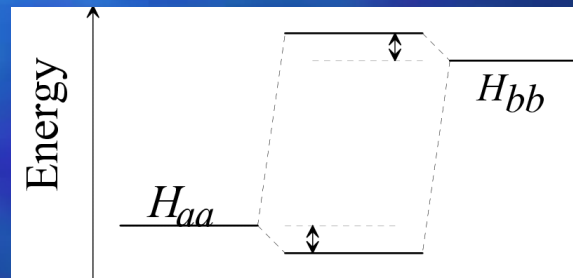

: ionic bond

Large binding energy is due to ...

- large difference between energy levels
or
- large overlap of wave functions

$$H_{aa} = \int \chi_a H \chi_a d\tau$$

$$H_{bb} = \int \chi_b H \chi_b d\tau$$

$$H_{ab} = \int \chi_a H \chi_b d\tau$$

$$S_{ab} = \int \chi_a \chi_b d\tau$$

σ -bond

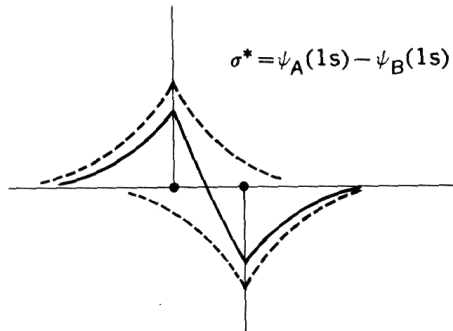
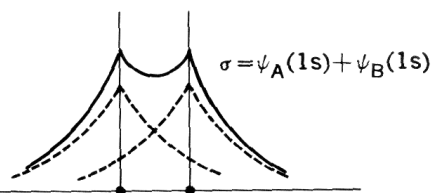

(b) In-phase, bonding MO combination

(c) Out-of-phase, antibonding MO combination

Figure 4-1 Approximate molecular orbitals in H_2 . (Phase relationships are shown by shading in the probability plots.)

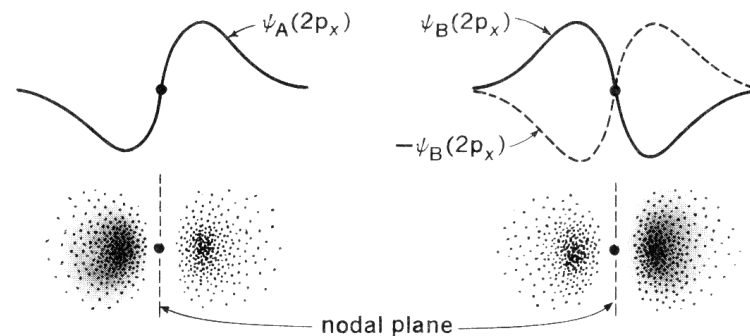

(a) Separated H atoms in $2p_x$ state

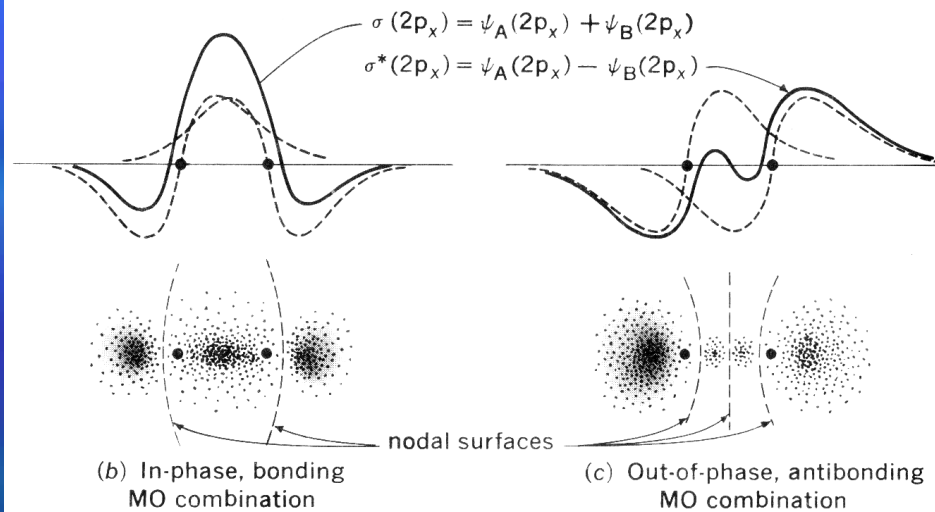

(b) In-phase, bonding MO combination

(c) Out-of-phase, antibonding MO combination

Figure 4-3 Sigma molecular orbitals from axial p orbitals. (The relative phases of the wave functions are shown by shading.)

" π -bond"

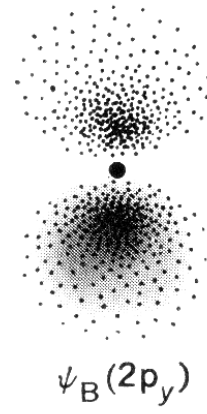
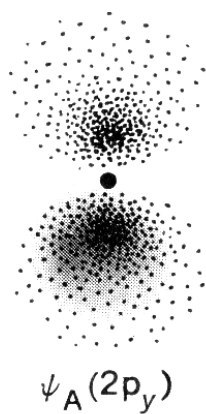

(a) Separated H atoms in $2p_y$ state

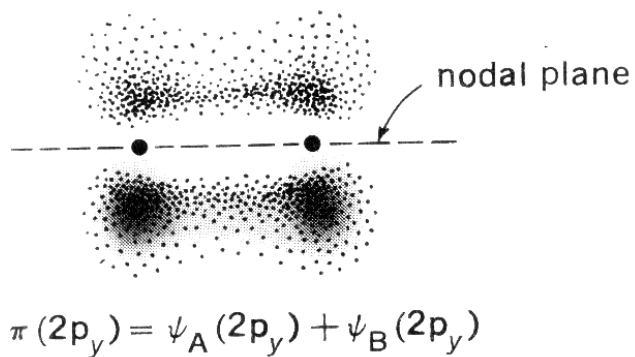

(b) In-phase, bonding MO combination

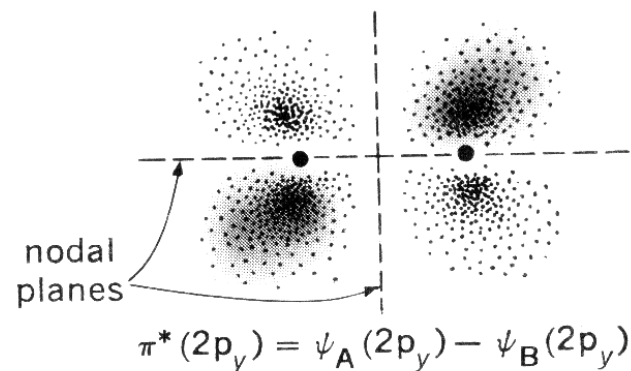

(c) Out-of-phase antibonding MO combination

Figure 4-4 Pi molecular orbitals from perpendicular p orbitals. (The relative phases of the wave functions are shown by shading.)

	<i>s</i>		<i>d</i>										<i>p</i>					
	1	2	1	2	3	4	5	6	7	8	9	10	1	2	3	4	5	6
	IA	IIA	IIIA	IVA	VA	VIA	VIIA	VIII			IB	IIB	IIIB	IVB	VB	VIB	VIIB	0
1	H																He	
2	Li	Be											B	C	N	O	F	Ne
3	Na	Mg											Al	Si	P	S	Cl	Ar
4	K	Ca	Sc	Ti	V	Cr	Mn	Fe	Co	Ni	Cu	Zn	Ga	Ge	As	Se	Br	Kr
5	Rb	Sr	Y	Zr	Nb	Mo	Tc	Ru	Rh	Pd	Ag	Cd	In	Sn	Sb	Te	I	Xe
6	Cs	Ba	*	Hf	Ta	W	Re	Os	Ir	Pt	Au	Hg	Tl	Pb	Bi	Po	At	Rn
7	Fr	Ra	**															

		<i>f</i>														
		1	2	3	4	5	6	7	8	9	10	11	12	13	14	
6	*	La	Ce	Pr	Nd	Pm	Sm	Eu	Gd	Tb	Dy	Ho	Er	Tm	Yb	Lu
7	**	Ac	Th	Pa	U	Np	Pu	Am	Cm	Bk	Cf	Es	Fm	Md	No	Lr

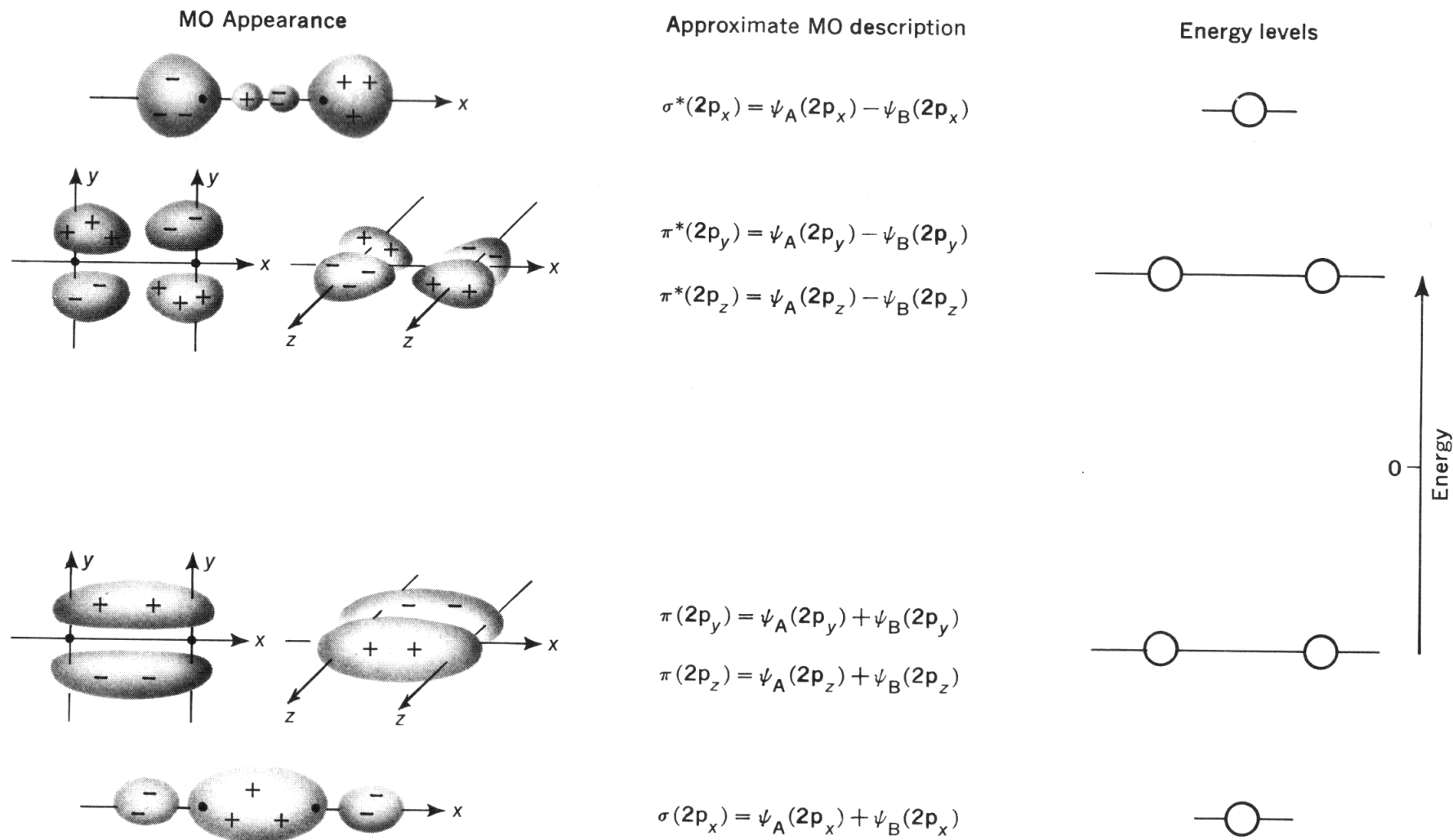

Figure 4-5 Molecular orbitals from 2p orbitals. The boundaries represent approximately the 95 percent probability surface. Within, there is a 95 percent chance of finding an electron. The relative phases are shown by plus and minus signs. These signs have nothing whatsoever to do with charge—they simply point out that the wave function which describes the orbitals has phase properties.

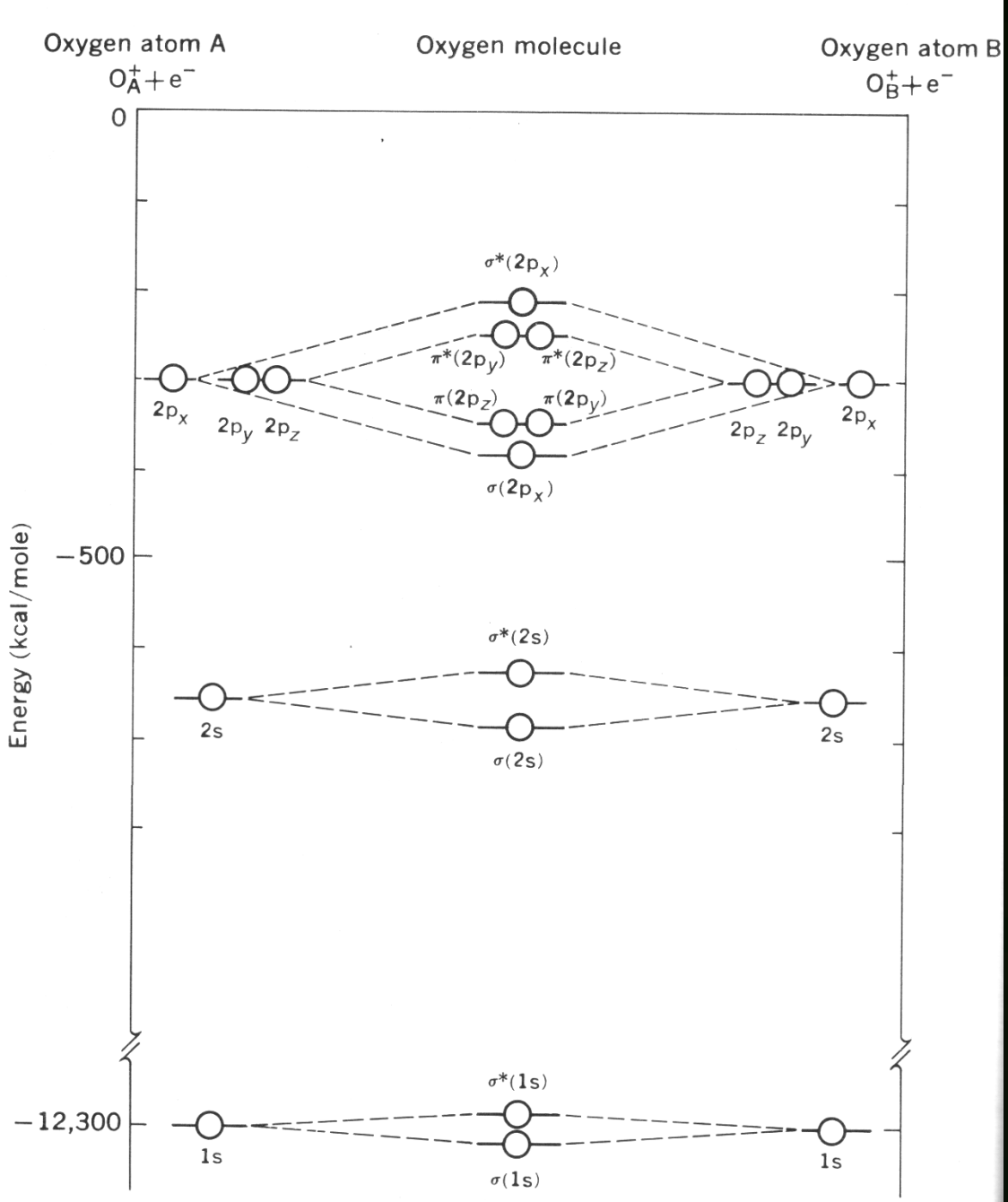
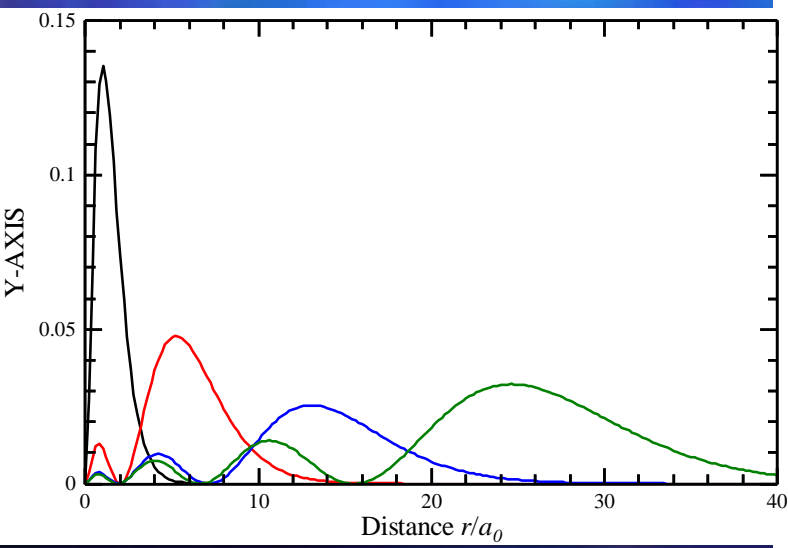

Figure 4-7 Molecular orbitals for O_2 .

	B ₂	C ₂	N ₂	O ₂	F ₂	Ne ₂	
$\sigma^*(2p_x)$ $\pi^*(2p_y) \pi^*(2p_z)$							
$\sigma(2p_x)$ $\pi(2p_y) \pi(2p_z)$							$\pi(2p_y) \pi(2p_z)$ $\sigma(2p_x)$
$\sigma^*(2s)$ $\sigma(2s)$							
$\sigma^*(1s)$ $\sigma(1s)$							
<u>Predicted: Bond Order</u>	1 (single)	2 (double)	3 (triple)	2 (double)	1 (single)	0 (none)	

Experimental:

Bond energy (kcal/mole)	69	150	225	118	36	—
Bond length (Å)	1.59	1.24	1.10	1.21	1.44	—
Force constant (mdyne/Å)	3.5	9.3	22.4	11.4	4.5	—
Magnetic	yes	no	no	yes	no	—

Figure 4-11 Orbital occupancies and bond properties of first-row homonuclear diatomic molecules.



	B ₂	C ₂	N ₂	O ₂	F ₂	Ne ₂
$\sigma^*(2p_x)$ $\pi^*(2p_y) \pi^*(2p_z)$						
$\sigma(2p_x)$ $\pi(2p_y) \pi(2p_z)$						
$\sigma^*(2s)$ $\sigma(2s)$						
$\sigma^*(1s)$ $\sigma(1s)$						
Predicted: Bond Order	1 (single)	2 (double)	3 (triple)	2 (double)	1 (single)	0 (none)
Experimental:						
Bond energy (kcal/mole)	69	150	225	118	36	—
Bond length (Å)	1.59	1.24	1.10	1.21	1.44	—
Force constant (mdyne/Å)	3.5	9.3	22.4	11.4	4.5	—
Magnetic	yes	no	no	yes	no	—

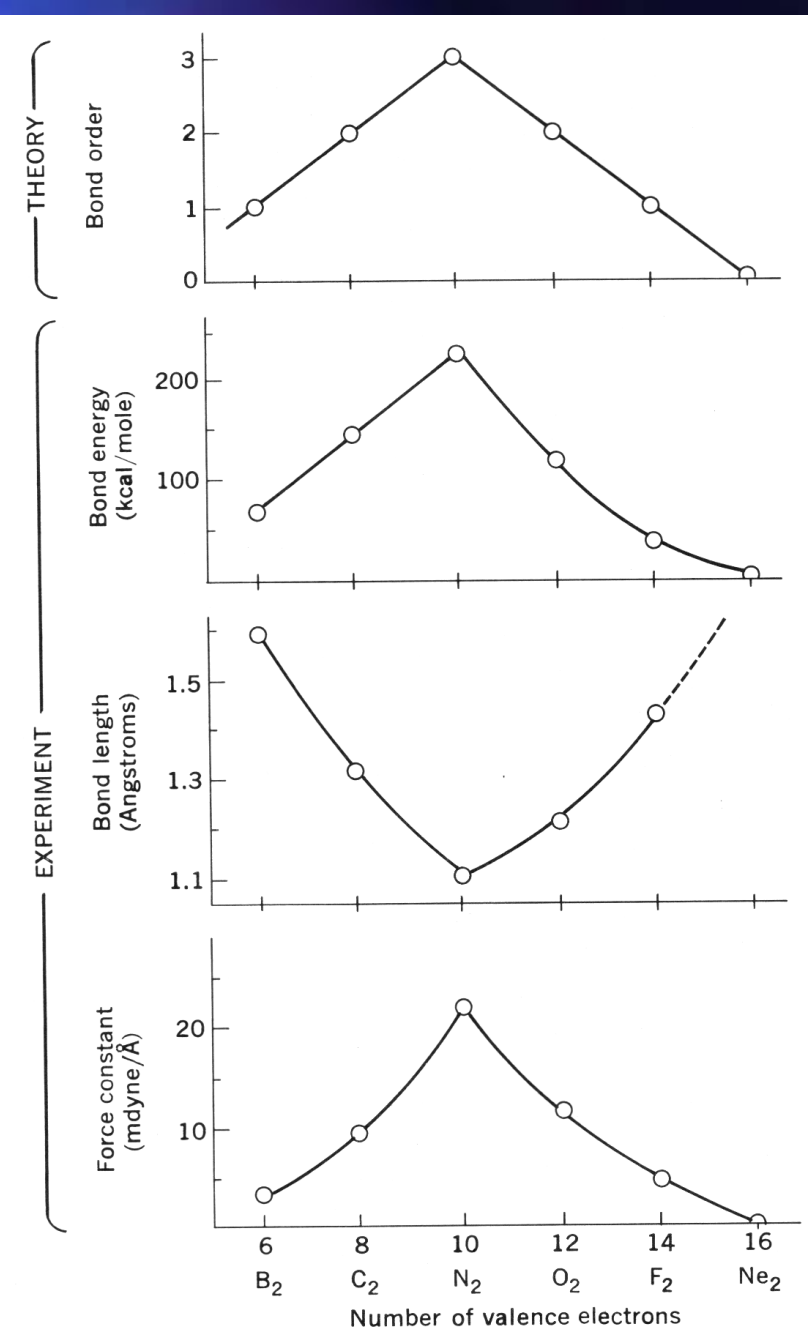

Figure 4-11 Orbital occupancies and bond properties of first-row homonuclear diatomic molecules.

Figure 4-12 Trends in bond properties and predicted bond orders in first-row homonuclear diatomic molecules.

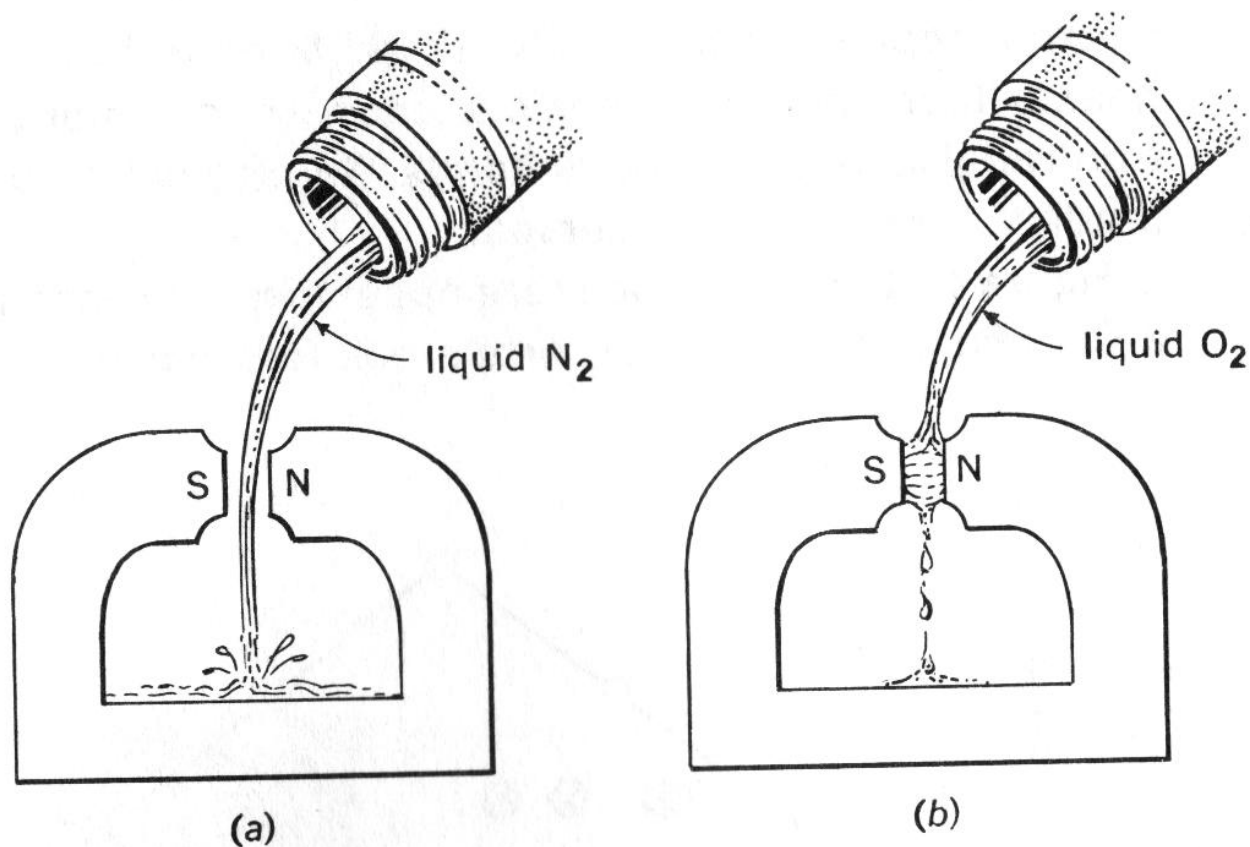
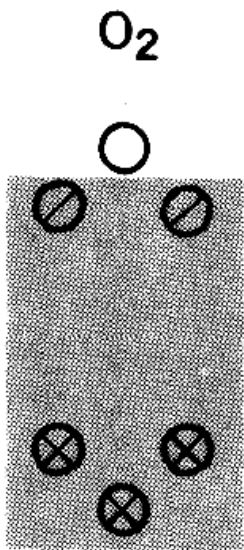

Figure 4-13 The oxygen molecule is magnetic, the nitrogen molecule is not. (a) Liquid nitrogen (bp = 77 degK) can be poured directly between the poles of a strong magnet. (b) Liquid oxygen (bp = 90 degK) is attracted by the magnet and fills up the gap between the two poles. This easily performed demonstration confirms the molecular orbital approach. Oxygen has two unpaired electrons (in antibonding orbitals) and is magnetic. Nitrogen has all its electrons paired and is not magnetic.

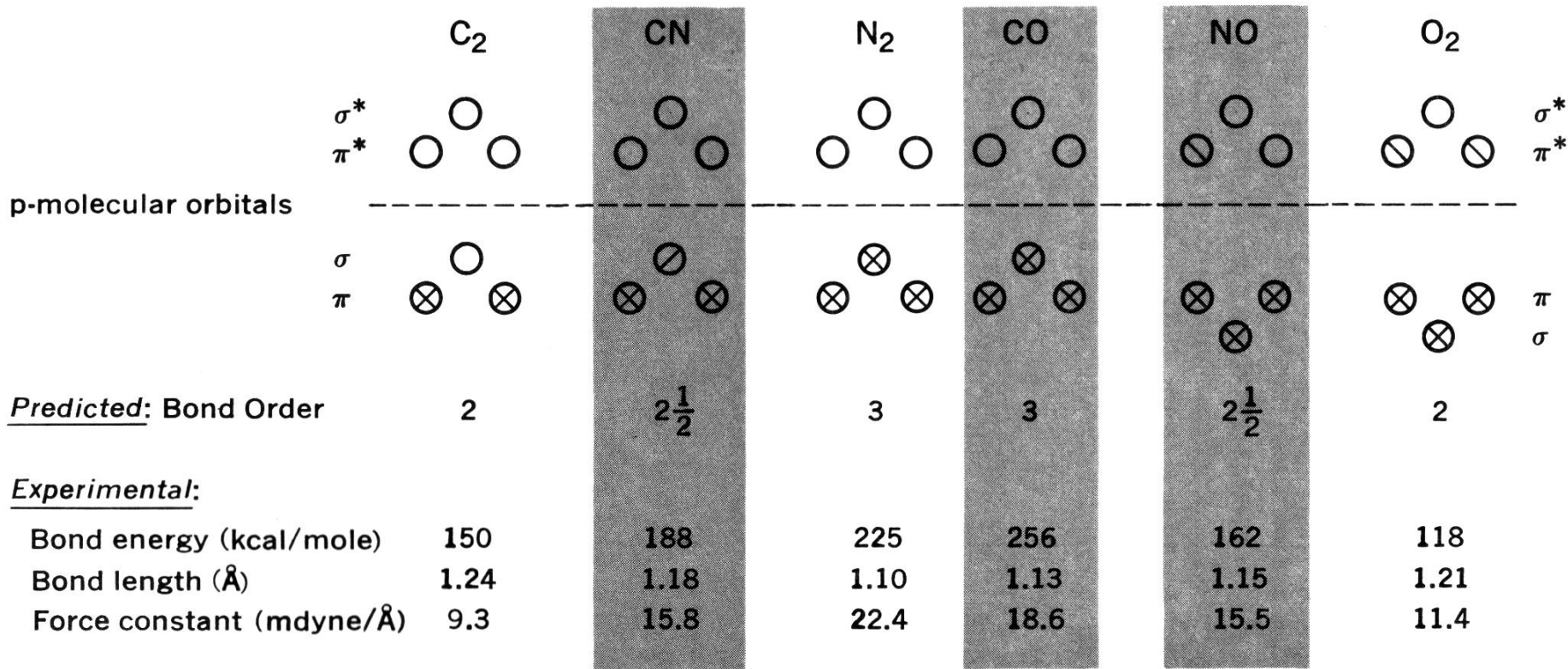

Figure 4-15 Orbital occupancy and bond properties of some heteronuclear diatomic molecules.

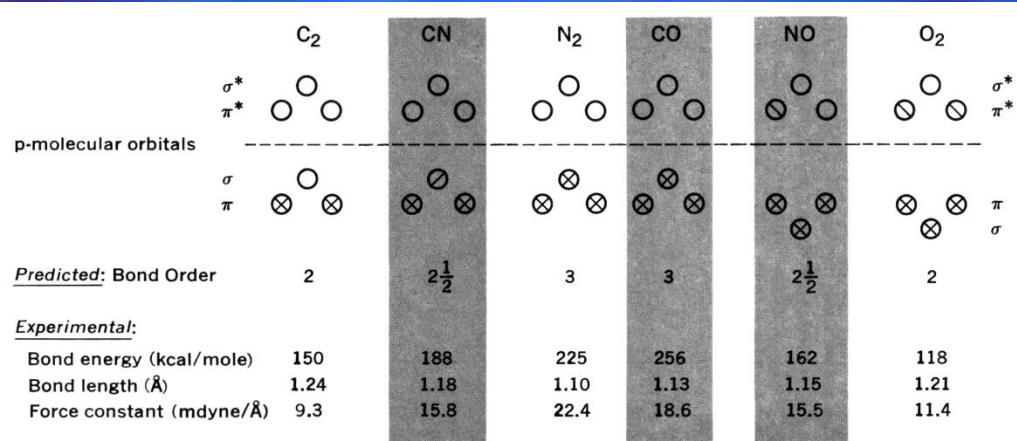

Figure 4-15 Orbital occupancy and bond properties of some heteronuclear diatomic molecules.

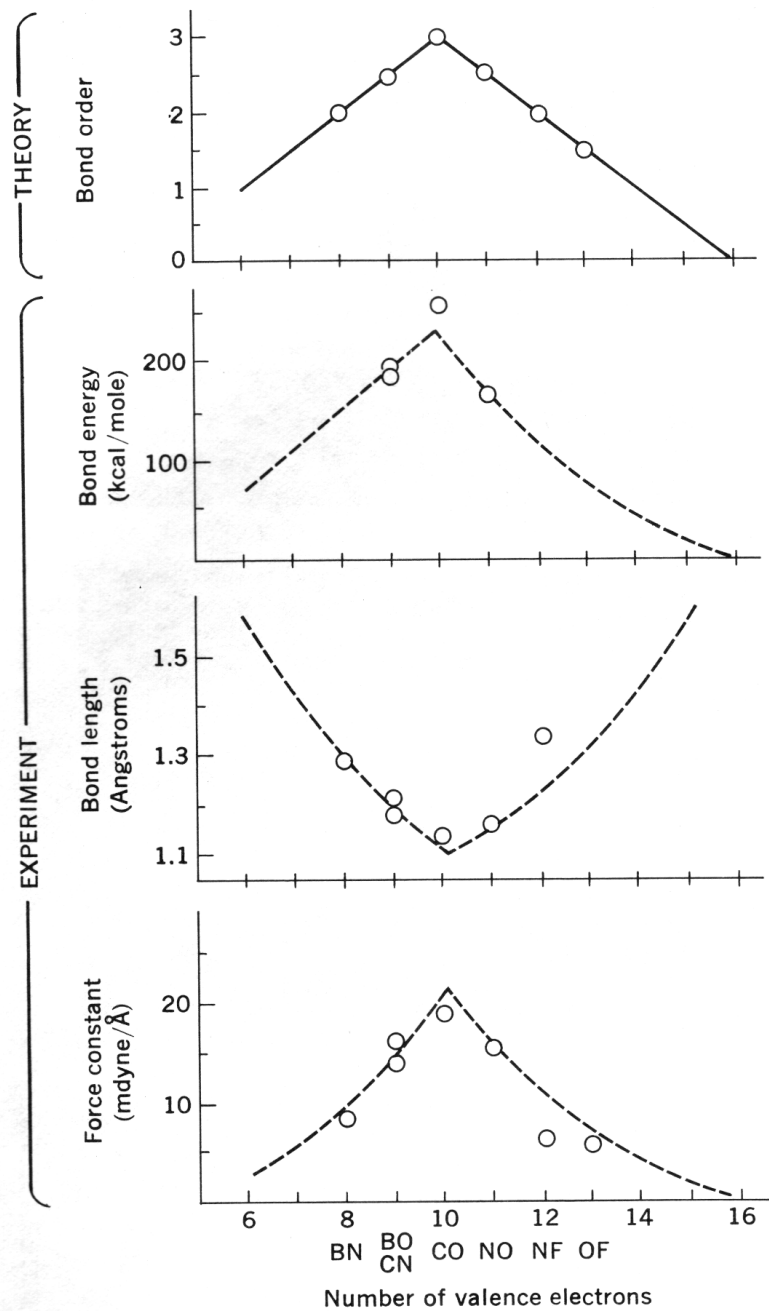

Figure 4-16 Trends in bond properties and predicted bond orders in first-row heteronuclear diatomic molecules.

11. Organic molecules

- Any Linear combination of atomic orbital is a solution of the wave equation.
- Also atomic orbital can be approximated to be a LCAO, as is used in Roothaan Hartree Fock approximation.



- A set of **hybrid orbitals** is another set of atomic orbitals.

Hybrid orbitals

- sp^3

$$\psi_1 = \frac{1}{2}(\psi_{2s} + \psi_{2p_x} + \psi_{2p_y} + \psi_{2p_z})$$

$$\psi_2 = \frac{1}{2}(\psi_{2s} + \psi_{2p_x} - \psi_{2p_y} - \psi_{2p_z})$$

$$\psi_3 = \frac{1}{2}(\psi_{2s} - \psi_{2p_x} + \psi_{2p_y} - \psi_{2p_z})$$

$$\psi_4 = \frac{1}{2}(\psi_{2s} - \psi_{2p_x} - \psi_{2p_y} + \psi_{2p_z})$$

- sp^2

$$\psi_1 = \sqrt{1/3}\psi_{2s} + \sqrt{2/3}\psi_{2p_x}$$

$$\psi_2 = \sqrt{1/3}\psi_{2s} - \sqrt{1/6}\psi_{2p_x} + \sqrt{1/2}\psi_{2p_y}$$

$$\psi_3 = \sqrt{1/3}\psi_{2s} - \sqrt{1/6}\psi_{2p_x} - \sqrt{1/2}\psi_{2p_y}$$

- sp

$$\psi_1 = \frac{1}{\sqrt{2}}\psi_{2s} + \frac{1}{\sqrt{2}}\psi_{2p_x}$$

$$\psi_2 = \frac{1}{\sqrt{2}}\psi_{2s} - \frac{1}{\sqrt{2}}\psi_{2p_x}$$

Hybrid orbitals

■ sp^3

$$\psi_1 = \frac{1}{2}(\psi_{2s} + \psi_{2p_x} + \psi_{2p_y} + \psi_{2p_z})$$

$$\psi_2 = \frac{1}{2}(\psi_{2s} + \psi_{2p_x} - \psi_{2p_y} - \psi_{2p_z})$$

$$\psi_3 = \frac{1}{2}(\psi_{2s} - \psi_{2p_x} + \psi_{2p_y} - \psi_{2p_z})$$

$$\psi_4 = \frac{1}{2}(\psi_{2s} - \psi_{2p_x} - \psi_{2p_y} + \psi_{2p_z})$$

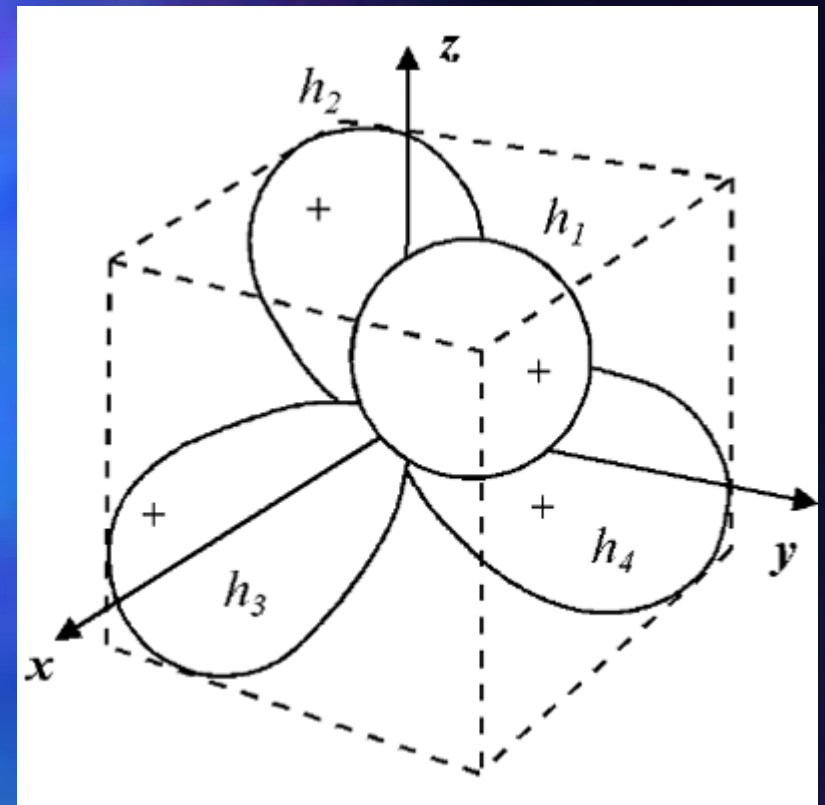

C : $(2s)^2(2p)^2 \rightarrow (sp^3)^4$

ex.

Methane (CH_4), Ethane ($\text{H}_3\text{C}-\text{CH}_3$), Methyl group ($\text{H}_3\text{C}-$), Si, C (diamond), etc...

■ sp^2

■ sp

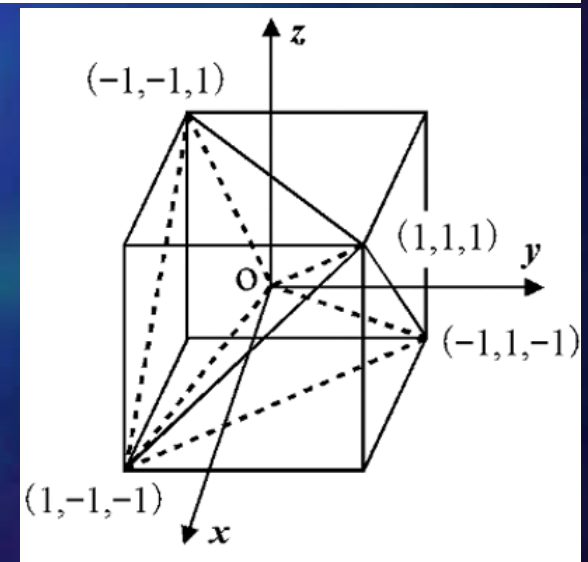

Hybrid orbitals

- sp^3
- sp^2

$$\psi_1 = \sqrt{1/3}\psi_{2s} + \sqrt{2/3}\psi_{2p_x}$$

$$\psi_2 = \sqrt{1/3}\psi_{2s} - \sqrt{1/6}\psi_{2p_x} + \sqrt{1/2}\psi_{2p_y}$$

$$\psi_3 = \sqrt{1/3}\psi_{2s} - \sqrt{1/6}\psi_{2p_x} - \sqrt{1/2}\psi_{2p_y}$$

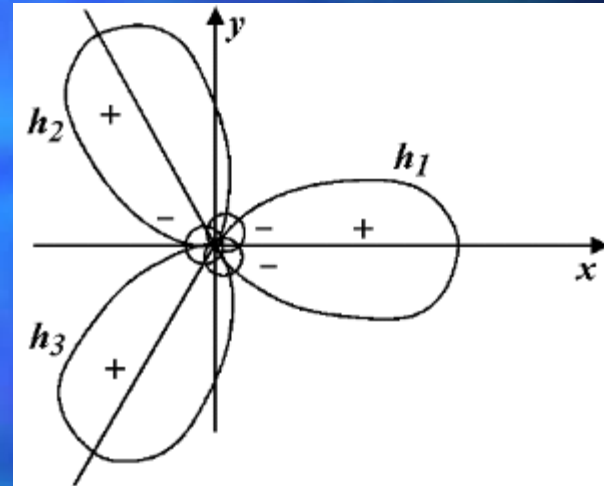

ex.

Ethylene (Methene, $H_2C=CH_2$), Methylene group ($H_2C=$), etc...

- sp

Hybrid orbitals

- sp^3
- sp^2
- **sp**

$$\psi_1 = \frac{1}{\sqrt{2}}\psi_{2s} + \frac{1}{\sqrt{2}}\psi_{2p_x}$$

$$\psi_2 = \frac{1}{\sqrt{2}}\psi_{2s} - \frac{1}{\sqrt{2}}\psi_{2p_x}$$

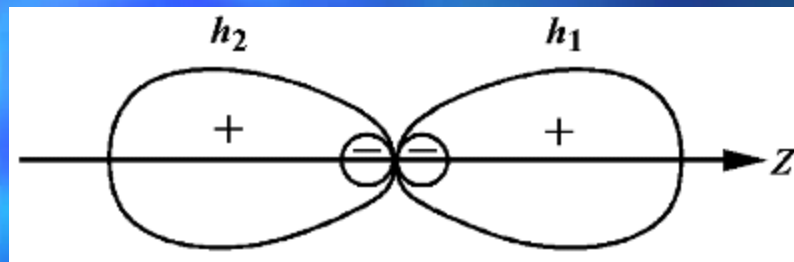
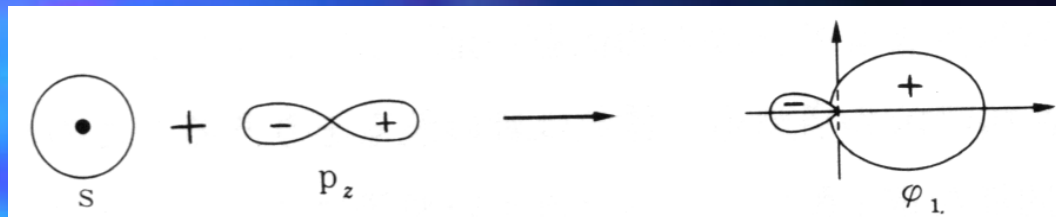

ex.

Acetylene (Ethyne, $HC\equiv CH$), Mtehine group ($HC\equiv$), etc...

Hybrid orbitals

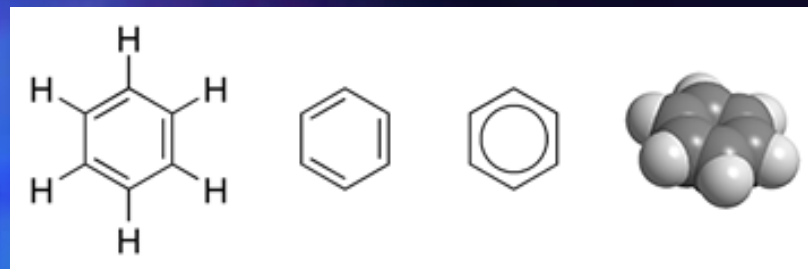

- sp^3
Methane (CH_4), Ethane (H_3C-CH_3), Methyl group (H_3C-),
Si, C (diamond), etc...
- sp^2
Ethylene (Methene, $H_2C=CH_2$), Methylene group ($H_2C=$), etc...
- sp
Acetylene (Ethyne, $HC\equiv CH$), Methylene group ($HC\equiv$), etc...

Others

- Benzene (C_6H_6), Cyclo-hexane (C_6H_{12})
- Methyl alcohol (CH_3OH)
- 1-Buten (α -Butylene, $H_2C=CHCH_2CH_3$)

12. Multi-atomic molecules

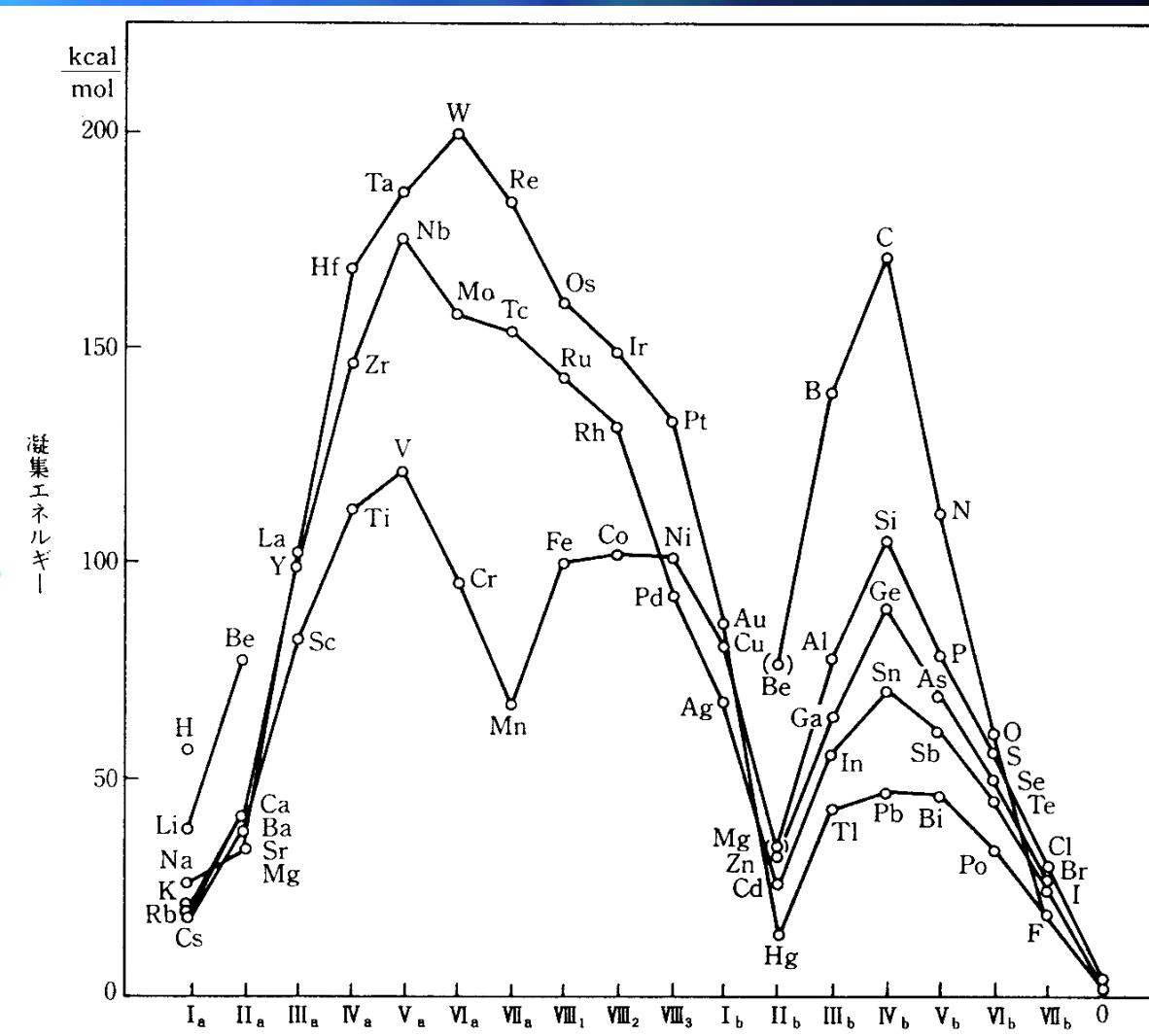
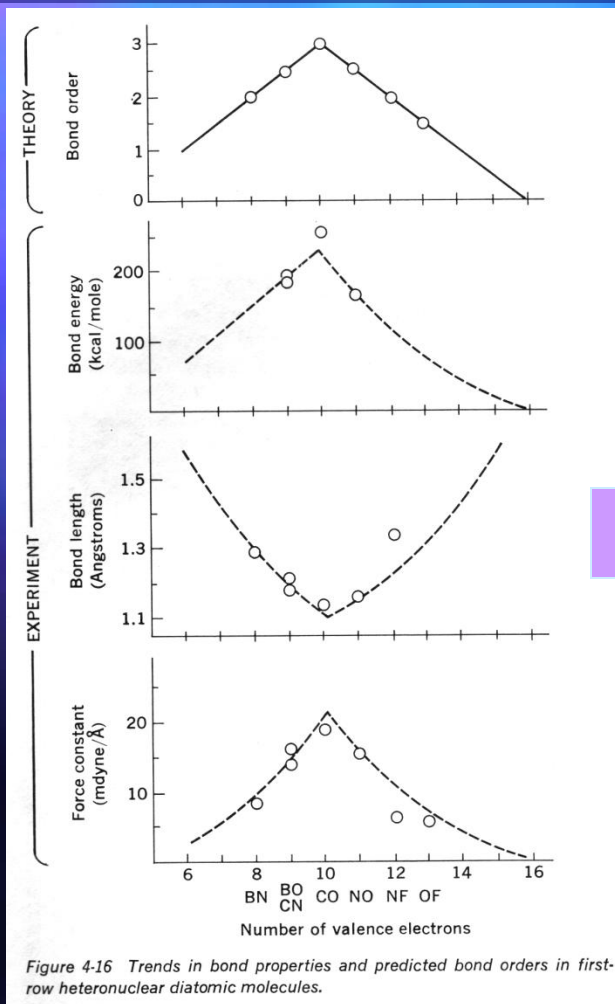

13. Jellium

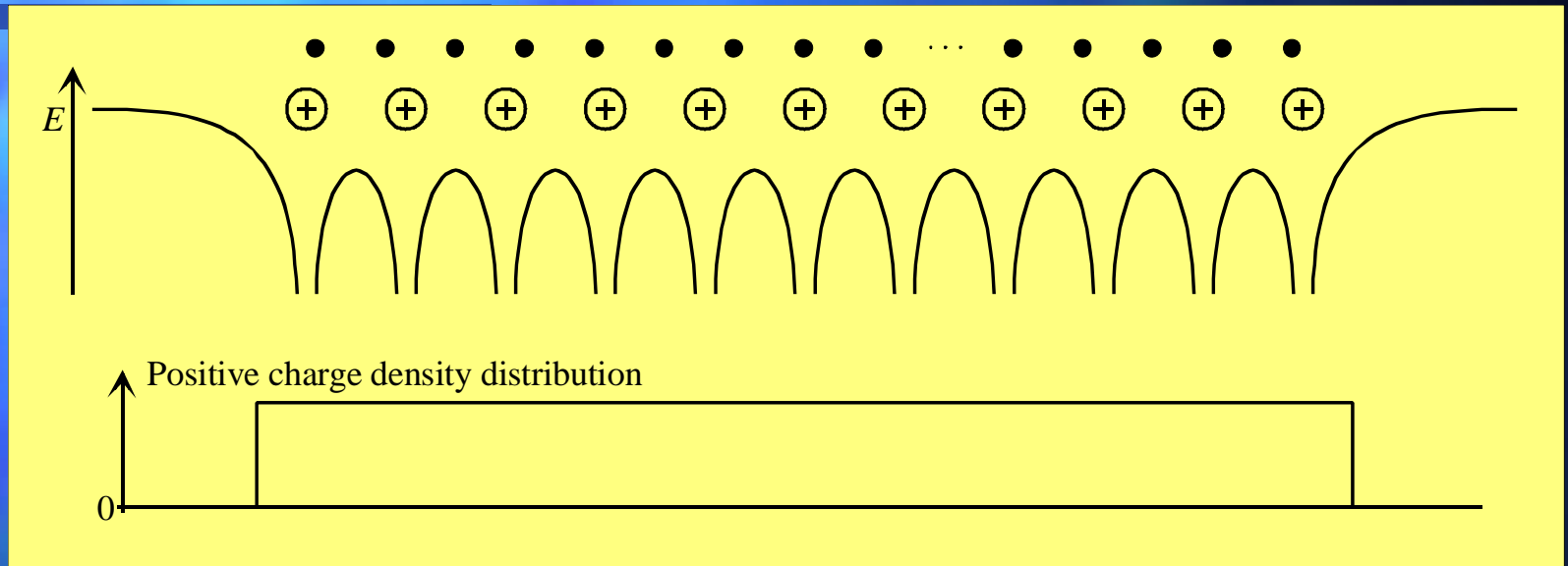

- Positive charge density distribution
- Electron distribution -> negative charge density distribution
- Total charge density distribution
- Electric field distribution
- Potential energy that electrons see.

Surface energy Surface tension

by K.Takahashi, and T.Onzawa,
Physical Review B, 48, 5689 (1993)

- One electron approximation
- Effective potential energy

$$H\Psi = \varepsilon\Psi$$

$$H = -\frac{\hbar^2}{2m}\nabla^2 + v_{\text{eff}}$$

- Potential shift determined from charge neutrality

Analytic wave functions !!



Analytic formula for surface tension !!

$$\gamma_s(T=0) = \frac{\hbar^2 k_F^4}{5\pi m} K_r(r) \approx \frac{\hbar^2 k_F^4}{5\pi m} \cdot 3.35 \times 10^{-2} \pm 3\%$$

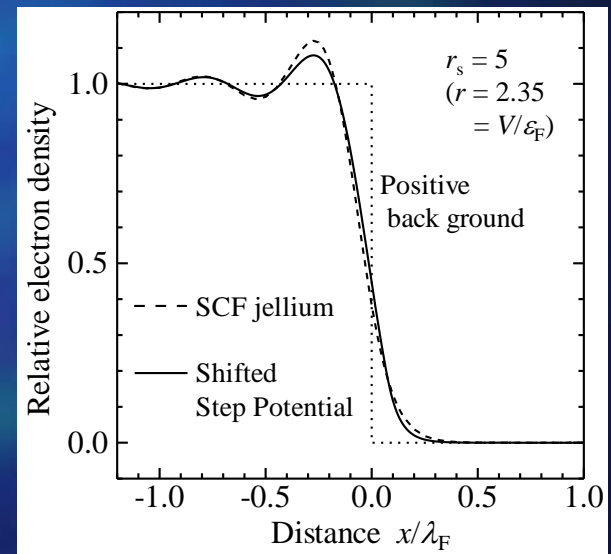
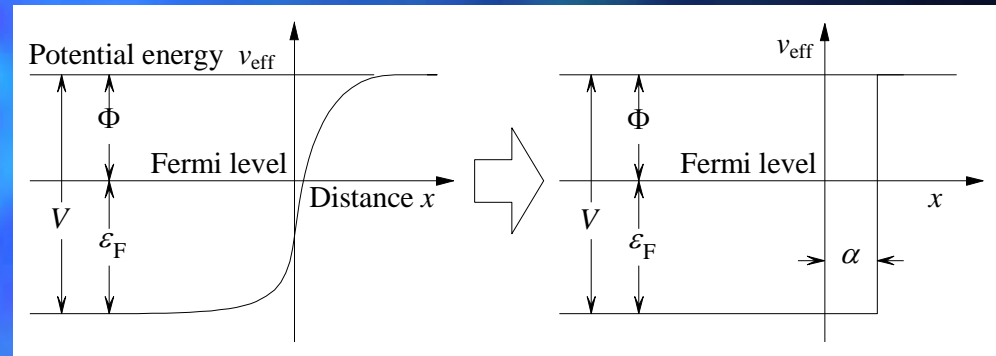

Theoretical approach for surface tension at 0 K

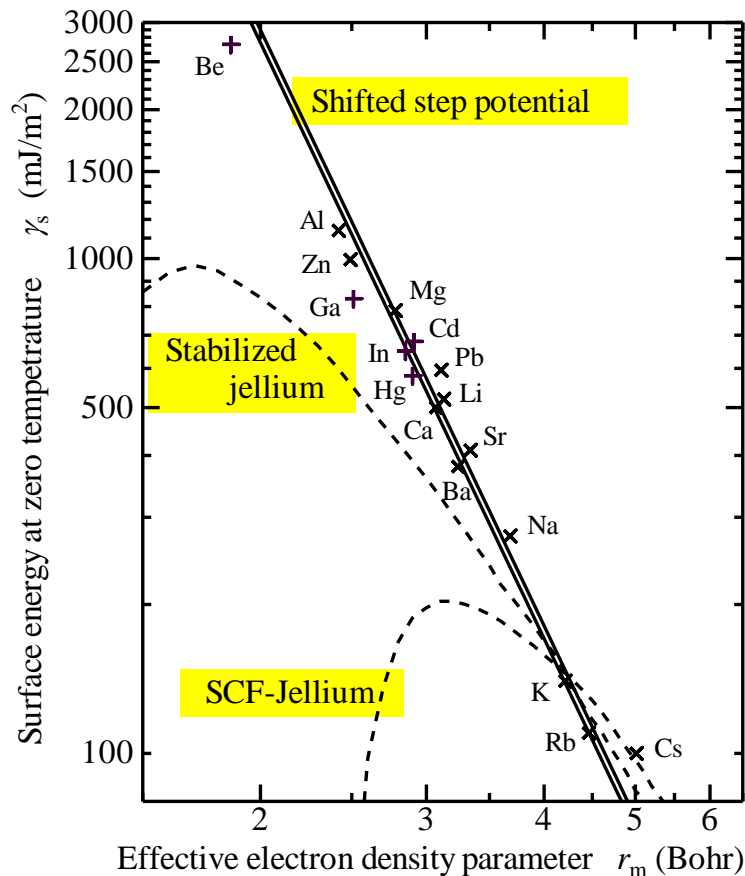

- **Shifted step potential**

K.Takahashi, and T.Onzawa,
Physical Review B, 48, 5689 (1993)

- **Stabilized jellium**

J.P.Predeur, H.Q.Tran and E.D.Smith,
Phys. Rev. B, 42, 11627 (1990).

- **SCF-jellium**

N.D.Lang and W.Kohn,
Phys. Rev. B, 1, 4555 (1970).

Surface energy (surface tension at 0 K)

by K.F.Wojciechowski, Surface Science, 437, 285-288 (1999)

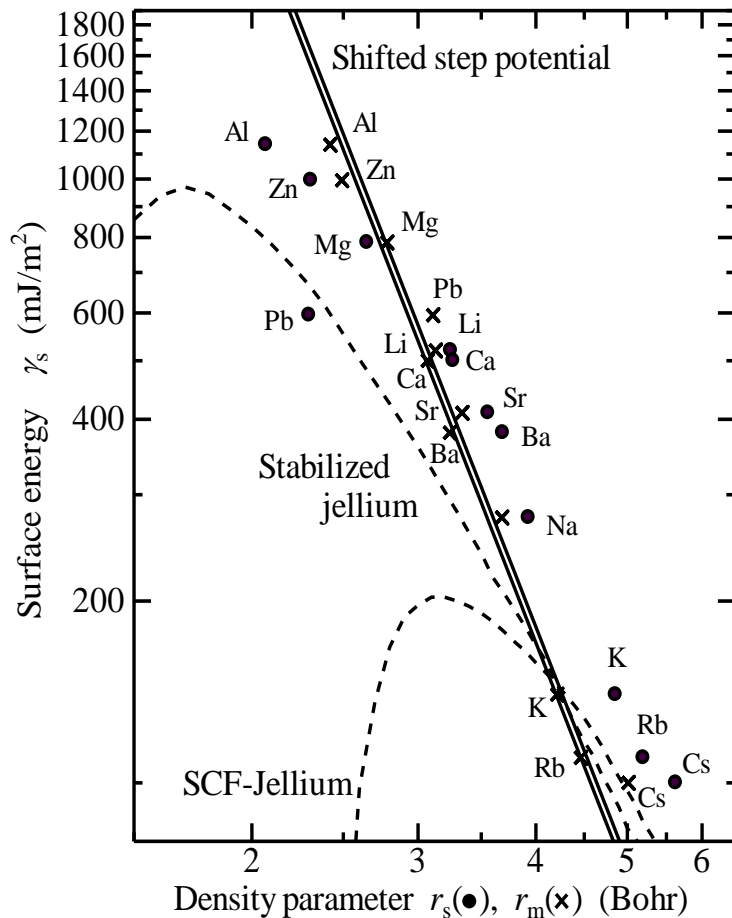

- **Shifted step potential**

K.Takahashi, and T.Onzawa,
Physical Review B, 48, 5689 (1993)

- **Stabilized jellium**

J.P.Predeur, H.Q.Tran and E.D.Smith,
Phys. Rev. B, 42, 11627 (1990).

- **SCF-jellium**

N.D.Lang and W.Kohn,
Phys. Rev. B, 1, 4555 (1970).

Limitation of density functional theory (DFT)

by K.F.Wojciechowski, Surface Science, 437, 285-288 (1999)

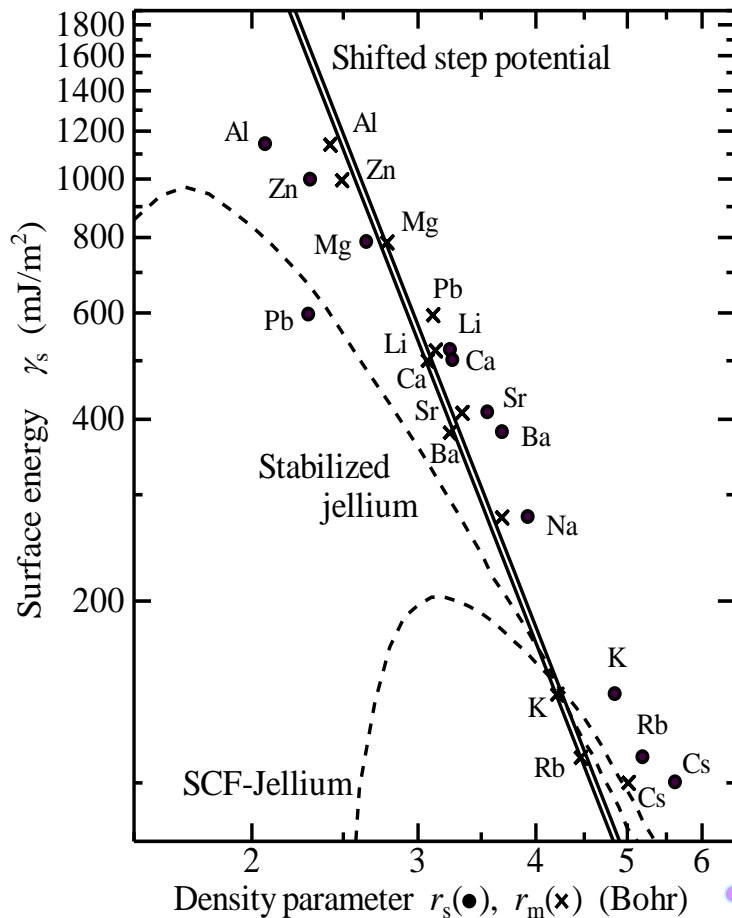

■ Extrapolation for liquid

as experimental values

■ Electron density

from

Kittel, *Introduction to Solid State Physics*, Wiley, New York, 1986

to

Perrot, F., and Rasolt, M., *J. Phys.: Cond. Matter*, 6, 1473-1482, 1994

Density parameter

-
Electron density

Electron density correction for jellium approximation

Density parameter from Kittel to Perrot

Valence no.	Metal	Electron density $\times 10^{22}$ (cm^{-3})	Density parameter	Fermi wave vector $\times 10^8$ (cm^{-1})	Fermi velocity $\times 10^8$ (cm/s)	Fermi energy (eV)	Fermi temp. $T_F \equiv \epsilon_F / k_B$ $\times 10^4$ (K)
1	Li	4.70	3.25	1.11	1.29	4.72	5.48
	Na	2.65	3.93	0.92	1.07	3.23	3.75
	K	1.40	4.86	0.75	0.86	2.12	2.46
	Rb	1.15	5.20	0.70	0.81	1.85	2.15
	Cs	0.91	5.63	0.64	0.75	1.58	1.83
2	Cu	8.45	2.67	1.36	1.57	7.00	8.12
	Ag	5.85	3.02	1.20	1.39	5.48	6.36
	Au	5.90	3.01	1.20	1.39	5.51	6.39
	Be	24.2	1.88	1.93	2.23	14.14	16.41
	Mg	8.60	2.65	1.37	1.58	7.13	8.27
	Ca	4.60	3.27	1.11	1.28	4.68	5.43
	Sr	3.56	3.56	1.02	1.18	3.95	4.58
	Ba	3.20	3.69	0.98	1.13	3.65	4.24
	Zn	13.10	2.31	1.57	1.82	9.39	10.9
	Cd	9.28	2.59	1.40	1.62	7.46	8.66
3	Al	18.06	2.07	1.75	2.02	11.63	13.49
	Ga	15.30	2.19	1.65	1.91	10.35	12.01
	In	11.49	2.41	1.50	1.74	8.60	9.98
4	Pb	13.20	2.30	1.57	1.82	9.37	10.87
	Sn(w)	14.48	2.23	1.62	1.88	10.03	11.64



Li	Be									Metal
3.13	1.86									r_m
3.07	1.85									r_s^*
Na	Mg	Al								
3.68	2.78	2.42								
3.67	2.58	2.12								
K	Ca	Sc	Ti	V	Cr	Mn	Fe	Co	Ni	
4.21	3.07	2.58	2.23	2.12	2.05	2.04	2.06	2.08	2.14	
4.37	2.96	2.33	2.00	1.80	1.71	1.70	1.71	1.74	1.83	
Cu	Zn	Ga								
2.25	2.49	2.51								
1.95	2.11	2.28								
Rb	Sr	Y	Zr	Nb	Mo	Tc	Ru	Rh	Pd	
4.46	3.34	2.69	2.44	2.38	2.23	2.21	2.23	2.29	2.39	
4.68	3.16	2.44	2.08	1.91	1.77	1.77	1.79	1.86	2.02	
Ag	Cd	In	Sn	Sb						
2.61	2.91	2.85	2.98	3.33						
2.23	2.44	2.57	-	-						
Cs	Ba	La	Hf	Ta	W	Re	Os	Ir	Pt	
5.01	3.24	2.89	2.47	2.36	2.27	2.21	2.21	2.26	2.37	
-	-	-	-	-	-	-	-	-	-	
Au	Hg	Tl	Pb	Bi						
2.54	2.90	3.04	3.11	3.48						
-	-	-	-	-						

r_m : determined so as to describe grand state property of arbitrary defects by Perrot
 r_s^* : determined from interstitial region by Moruzzi

Kittel, *Introduction to Solid State Physics*, Wiley, New York, 1986

Perrot, F., and Rasolt, M., *J. Phys.: Cond. Matter*, 6, 1473-1482, 1994

Limitation of density functional theory (DFT)

by K.F.Wojciechowski, Surface Science, 437, 285-288 (1999)

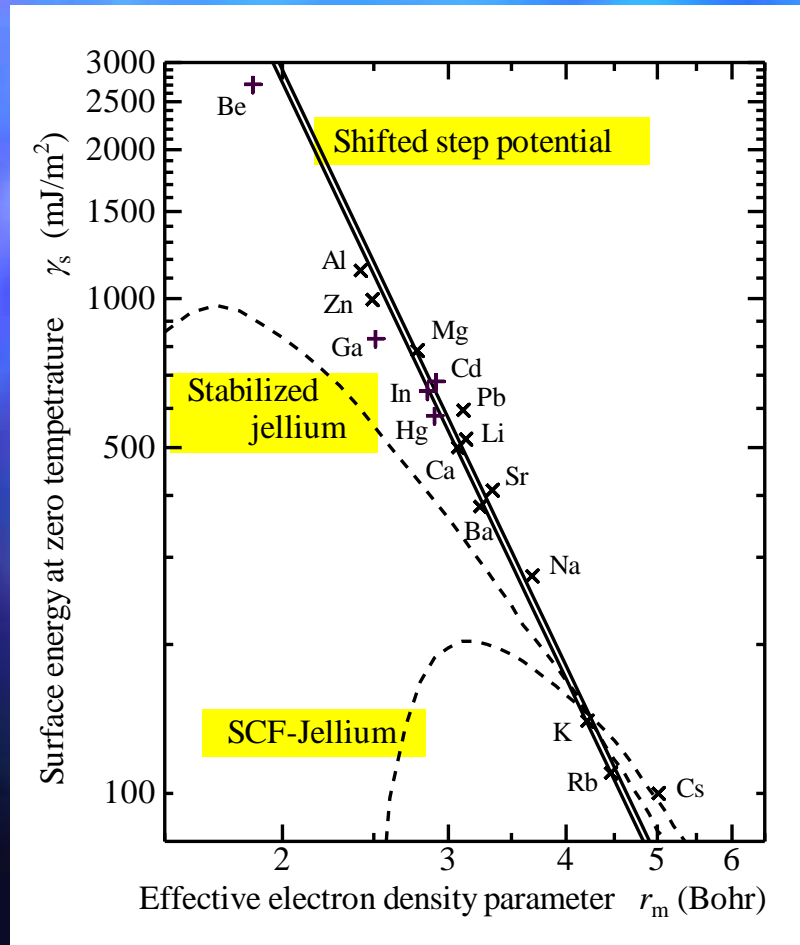

- **Shifted step potential**

K.Takahashi, and T.Onzawa,
Physical Review B, 48, 5689 (1993)

- **Stabilized jellium**

J.P.Predew, H.Q.Tran and E.D.Smith,
Phys. Rev. B, 42, 11627 (1990).

- **SCF-jellium**

N.D.Lang and W.Kohn,
Phys. Rev. B, 1, 4555 (1970).



Limitation of DFT

- **Surface tension:** Free energy required to create unit area of surface

γ_{surface}

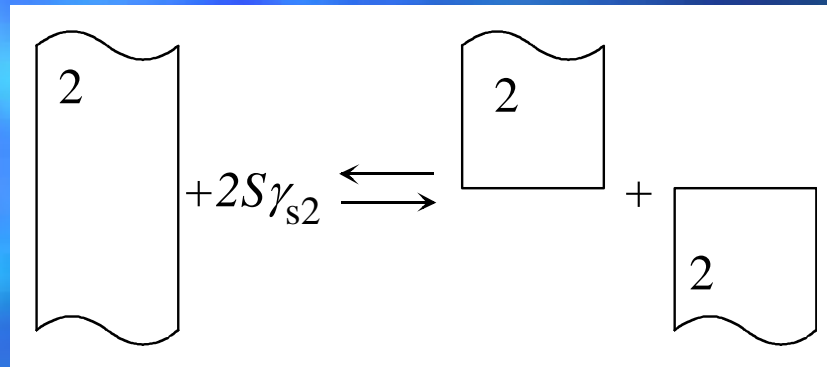
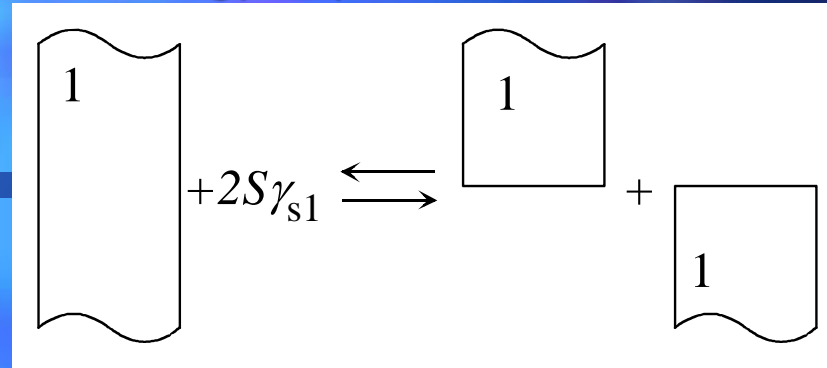

- **Interfacial tension :** Free energy required to create unit area of interface

$\gamma_{\text{interface}}$

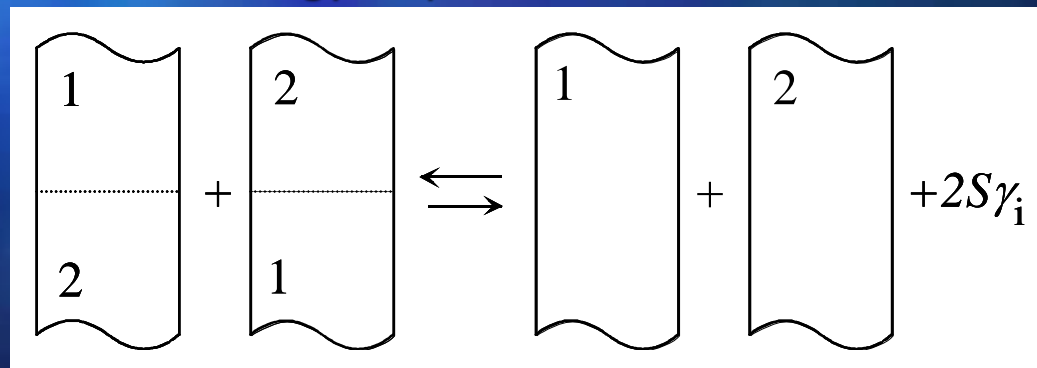

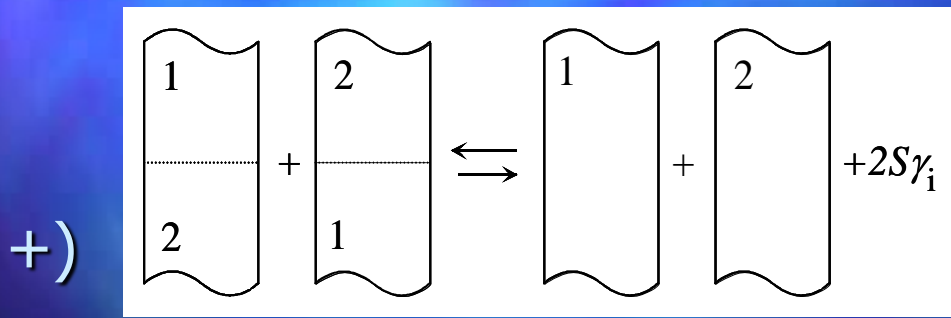
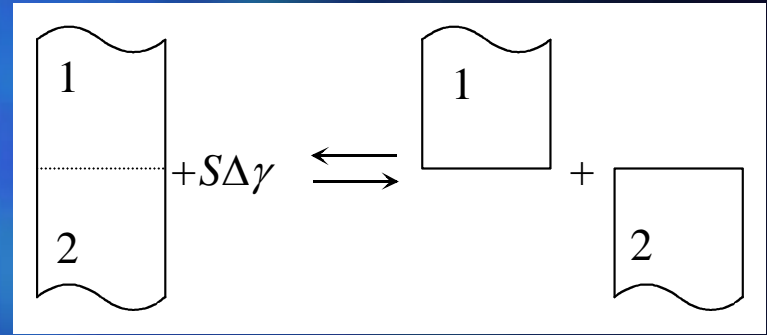
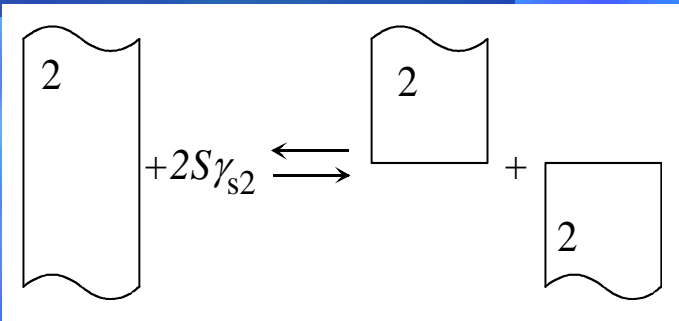
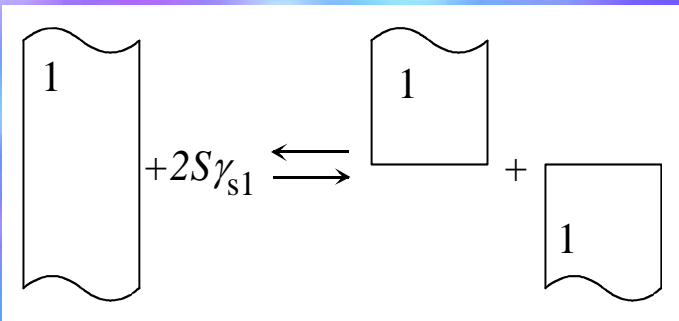

$$\Delta\gamma = \gamma_{\text{surface1}} + \gamma_{\text{surface2}} - \gamma_{\text{interface}}$$

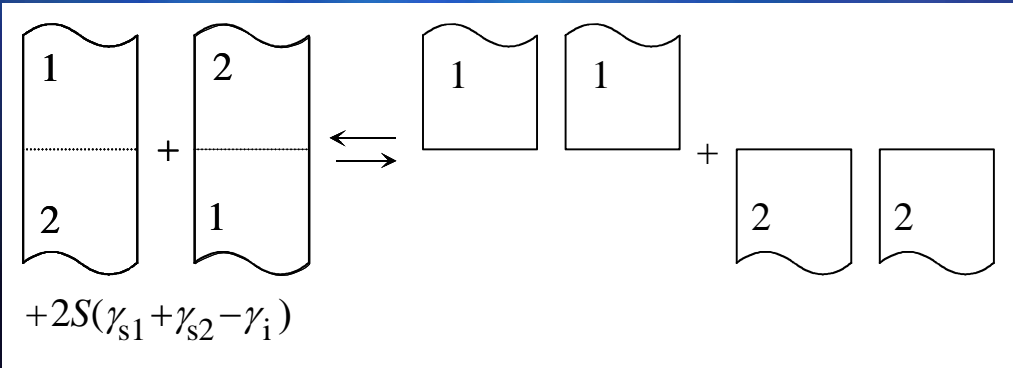

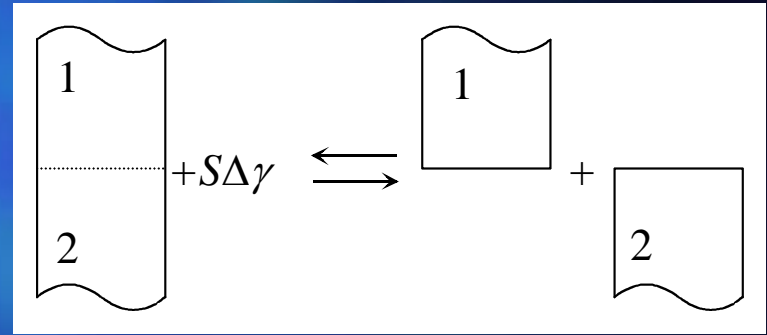
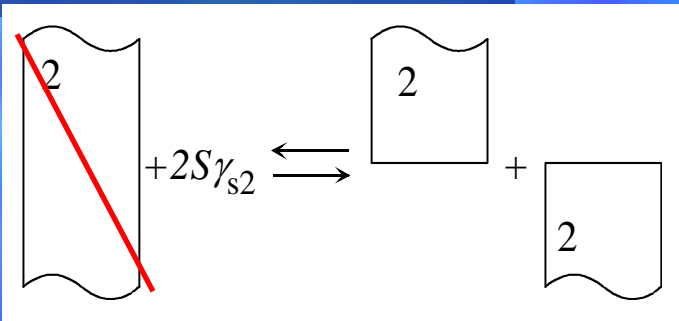
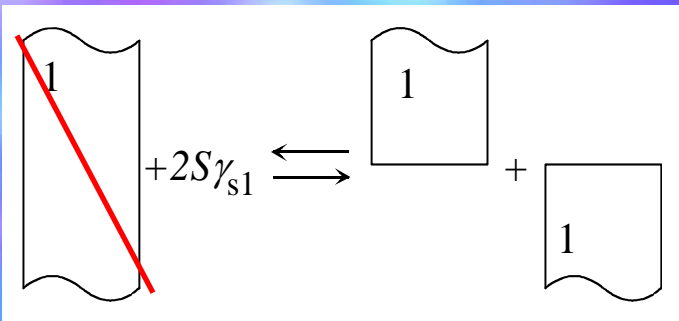

+))

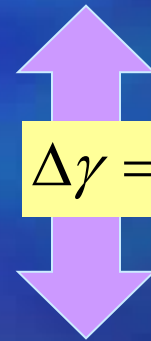
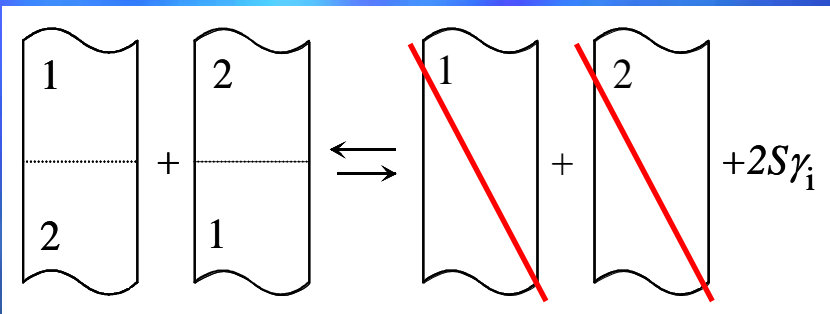

$$\Delta\gamma = \gamma_{\text{surface1}} + \gamma_{\text{surface2}} - \gamma_{\text{interface}}$$

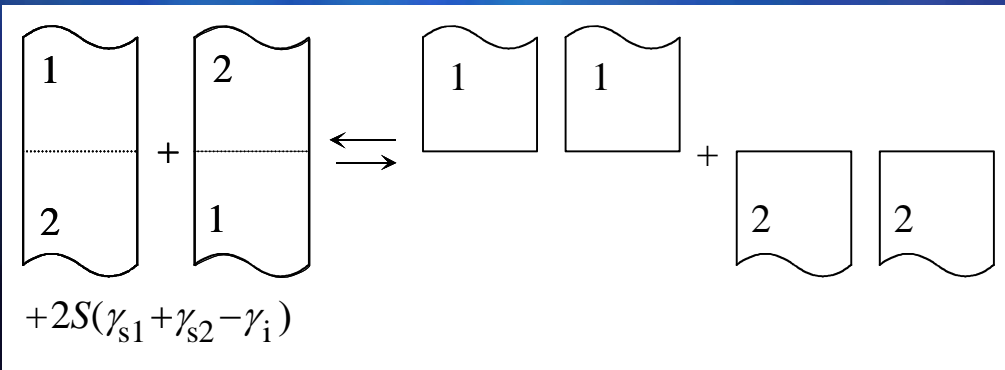

Work of adhesion



“Material **constant**”

from atomic interaction

Work of adhesion

Free energy required to separate unit area of adhered interface

$\Delta\gamma$

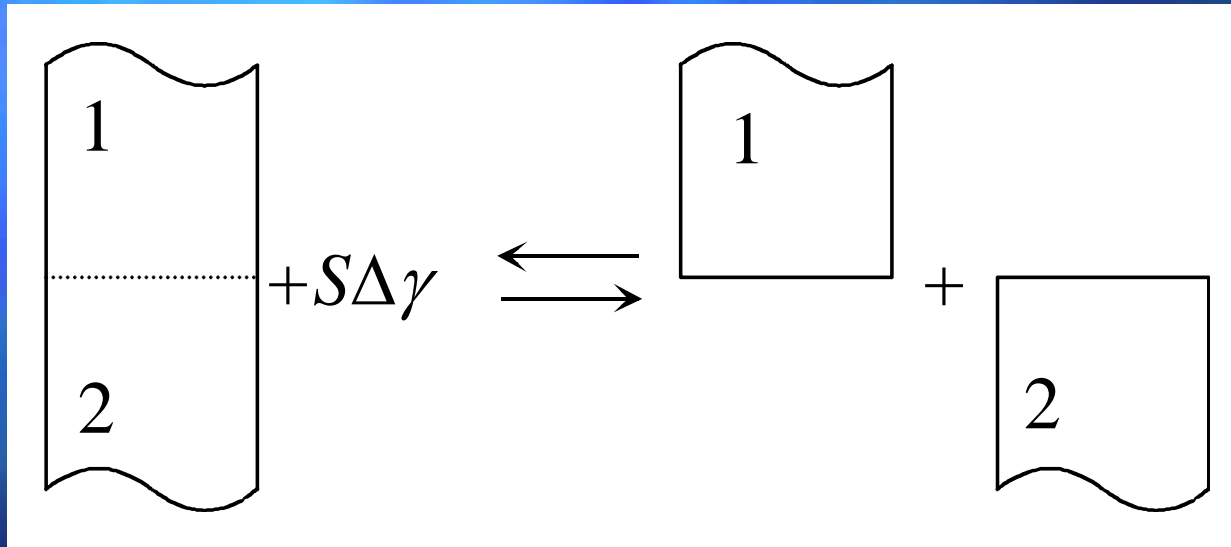

related

- Surface tension γ_s , Interfacial tension γ_i

Free energy required to create unit area of surface (interface)

Temperature dependence of interfacial/surface tension

- Internal energy and entropy

$$U_{\text{tot}} = U_{\text{b}} + U_{\text{s}} \quad S_{\text{tot}} = S_{\text{b}} + S_{\text{s}}$$

- 1st law and 2nd law of thermodynamics

$$dU_{\text{tot}} = TdS_{\text{tot}} - pdV_{\text{b}} + \gamma dA$$

- For bulk, $dU_{\text{b}} = TdS_{\text{b}} - pdV_{\text{b}}$

therefore $dU_{\text{s}} = TdS_{\text{s}} + \gamma dA$

- Variables for unit area of surface

$$U_{\text{s}} = U_{\text{s}}^{\gamma} A \quad S_{\text{s}} = S_{\text{s}}^{\gamma} A$$

- For arbitrary area of surface,

$$(U_{\text{s}}^{\gamma} - TS_{\text{s}}^{\gamma} - \gamma) dA + A(dU_{\text{s}}^{\gamma} - TdS_{\text{s}}^{\gamma}) = 0$$

Therefore, $\gamma = U_{\text{s}}^{\gamma} - TS_{\text{s}}^{\gamma} \quad dU_{\text{s}}^{\gamma} = TdS_{\text{s}}^{\gamma}$

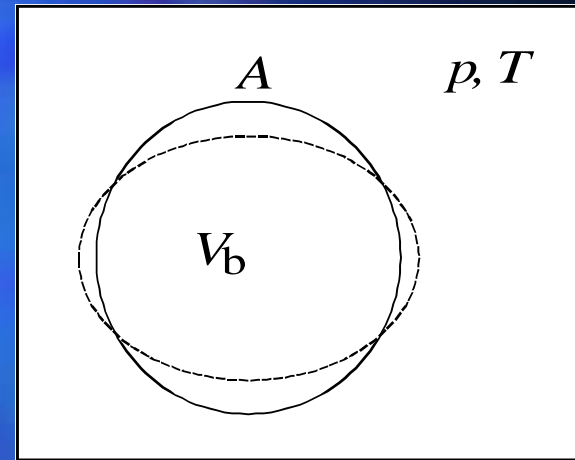

$$\begin{aligned} \gamma(p, T) &= U_{\text{s}}^{\gamma}(p, T) - TS_{\text{s}}^{\gamma}(p, T) \\ &= U_{\text{s}}^{\gamma} - T \int_0^T \frac{1}{T} \left(\frac{\partial U_{\text{s}}^{\gamma}}{\partial T} \right)_p dT \end{aligned}$$

$$S_{\text{s}}^{\gamma} = - \left(\frac{\partial \gamma}{\partial T} \right)_p$$



surface (interfacial) **free energy**
= surface (interfacial) **tension**

$$\begin{aligned}\gamma(p, T) &= U_s^\gamma(p, T) - TS_s^\gamma(p, T) \\ &= U_s^\gamma - T \int_0^T \frac{1}{T} \left(\frac{\partial U_s^\gamma}{\partial T} \right)_p dT\end{aligned}$$

surface (interfacial) **internal energy**
= surface (interfacial) **energy**
= surface (interfacial) **tension at 0 K.**

$$\gamma(p, T) = U_s^\gamma(p, T) - TS_s^\gamma(p, T)$$

$$= U_s^\gamma - T \int_0^T \frac{1}{T} \left(\frac{\partial U_s^\gamma}{\partial T} \right)_p dT$$

Theoretical approach for surface tension at 0 K

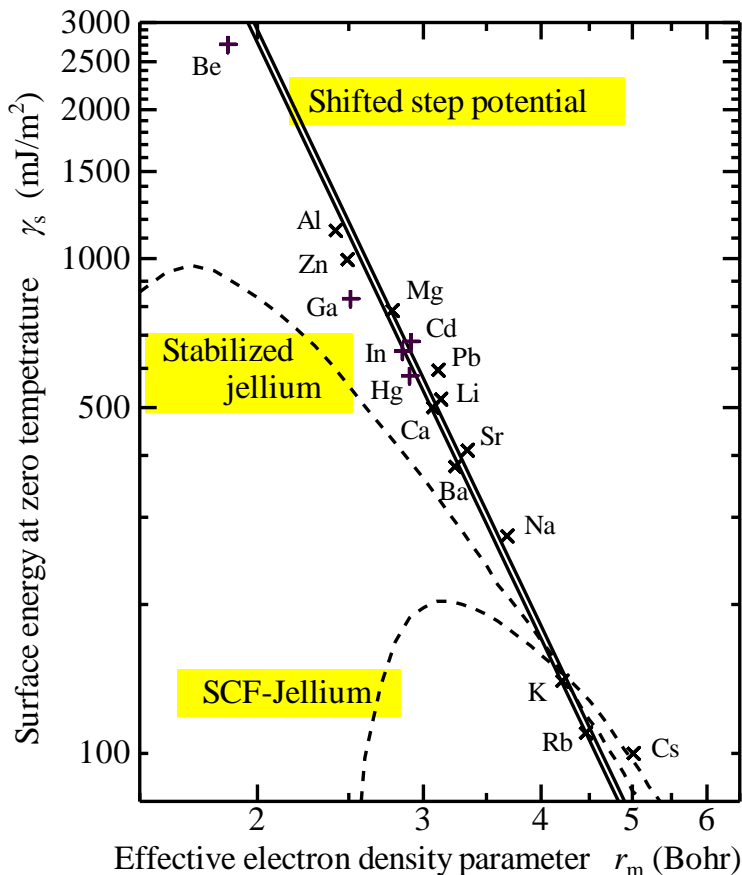

- Shifted step potential**
 K.Takahashi, and T.Onzawa,
 Physical Review B, 48, 5689 (1993)
- Stabilized jellium**
 J.P.Predew, H.Q.Tran and E.D.Smith,
 Phys. Rev. B, 42, 11627 (1990).
- SCF-jellium**
 N.D.Lang and W.Kohn,
 Phys. Rev. B, 1, 4555 (1970).

Temperature dependence of surface tension

- Other contributions
(phonon, phase transformation)

$$\gamma(p, T) = U_s^\gamma - T \int_0^T \frac{1}{T} \left(\frac{\partial U_s^\gamma}{\partial T} \right)_p dT$$

$$U_s^\gamma = U_{s, \text{electron}}^\gamma + U_{s, \text{phonon}}^\gamma + U_{s, \text{phase trans.}}^\gamma$$

=0, at 0 (zero) K.

$$U_{s, \text{electron}}^\gamma(T) = \frac{\hbar^2 k_F^4}{5\pi m} K_r(r, \tau)$$

